

BC 250 PM

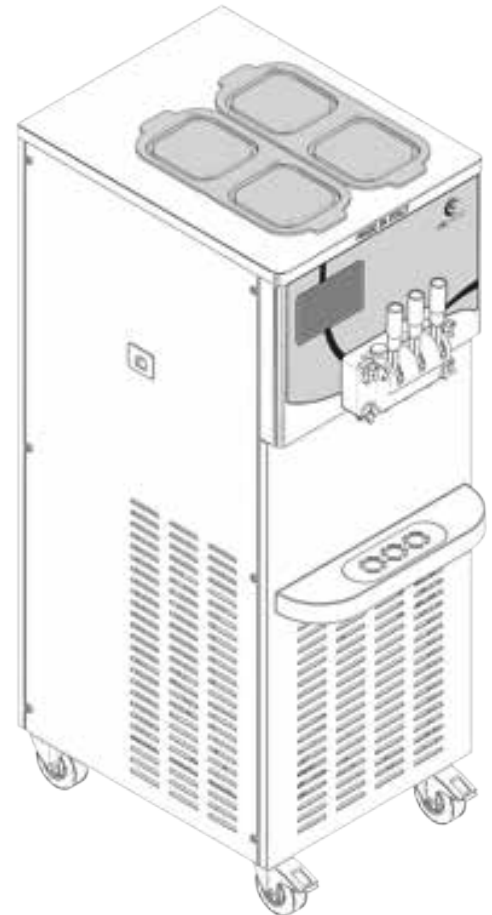

BV 250 PM

User and instruction manual

INDEX

1. Qualification of Personnel	4
2. Instructions for installation	5
3. Instructions for the operator	12
4. Safety	13
5. Identification of components	14
6. Instructions for operation	21

Note: the information contained in this manual is subject to modification without prior notice, due to on-going research.

**WARNING:
GENERIC HAZARD**

This symbol indicates that, before any operation, the safety prescriptions contained in this manual must be read thoroughly and complied with.

In case of doubt, contact only qualified personnel.



**WARNING:
RISK OF ELECTROCUTION**

This symbol indicates that, the described operation can present the risk of electrocution, if it is not carried out in compliance with safety prescriptions.



**WARNING:
SHARP EDGES**

This symbol indicates the presence of sharp edges, which can cause serious injury.



WARNING:

The machine shall be properly earthed.

Inobservance of these instructions can cause serious personal injury, due to electrocution.



NOTE:

This symbol indicates that the information is very important for the concerned personnel.



According to their level of education and responsibility, the personnel in charge of the machine can be:

OPERATOR

Person in charge of operating the machine, able to perform simple tasks, such as start-up of the machine, delivery of the final product, operations of product loading and unloading, cleaning operations and other simple basic maintenance operations.

The operator has no specific technical skills.

QUALIFIED TECHNICIAN

The existing regulations define as qualified technician a person who, for his expertise and experience, as well as knowledge of relevant standards, safety requirements and conditions of service, is able to recognize and avoid any possible damages to the machine and is authorized to perform all types of intervention by the Head of safety.

GEL MATIC TECHNICIAN

Qualified technician made available by the manufacturer for particularly complex interventions, in particular situations.

SAFETY INFORMATION

The machine has been designed and built according to the standards and foresight required to meet the main safety requirements prescribed by relevant EC directives and European harmonized standards (see EC Declaration of conformity supplied with the machine).

In all other countries outside the European Union, the machine must be installed in accordance with the regulations in force locally.

Contact local authorities in case of further questions about it.

The manufacturer cannot be held liable for consequent damage to people, things or animals, resulting from the failure to comply with safety regulations and warnings contained in the supplied documentation.

The trained technician responsible for installing the machine shall instruct the user appropriately on the safety measures to be adopted

The machine is not intended for use by persons (including children) with reduced physical, sensory or mental capabilities, or lack of experience and knowledge, unless they have been given supervision or instruction concerning the use of the unit by a person responsible for their safety.

Children should be supervised to ensure that they do not play with the machine.

The machine has moving parts that can reach high temperatures, and electrical parts that can cause serious damage to people or property.

The safety managers must also ensure that:

- maintenance operations are carried out regularly
- the documentation concerning the operation and maintenance of the machine is always available near the workplace.

2

INSTRUCTIONS FOR INSTALLATION INSTRUCTIONS POUR L'INSTALLATEUR

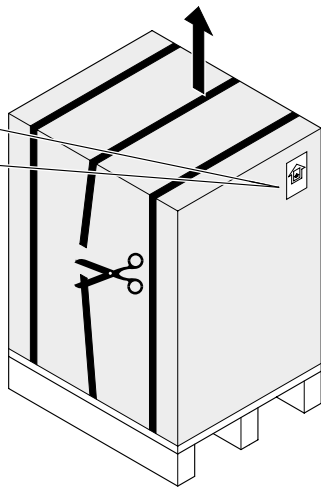

1

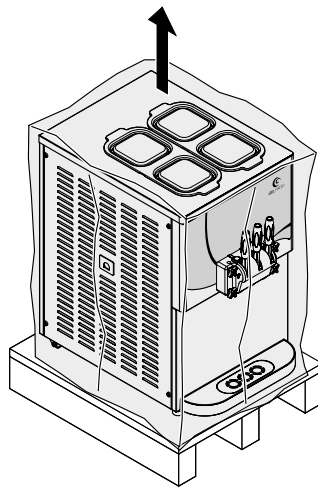

2

COUNTERTOP MACHINES

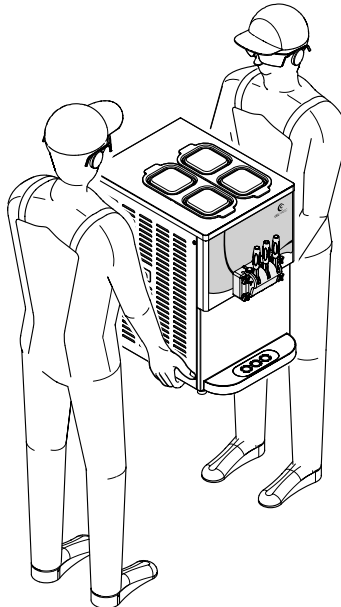
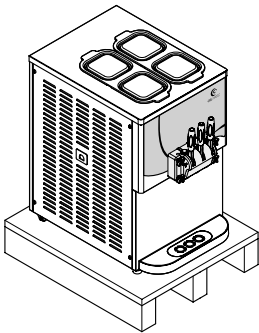

VERTICAL MACHINES

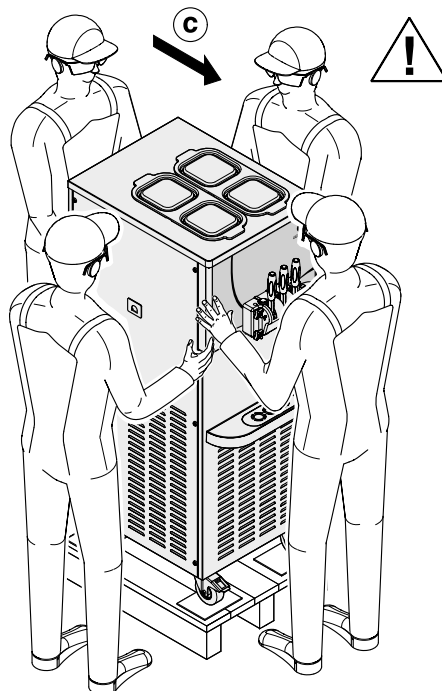
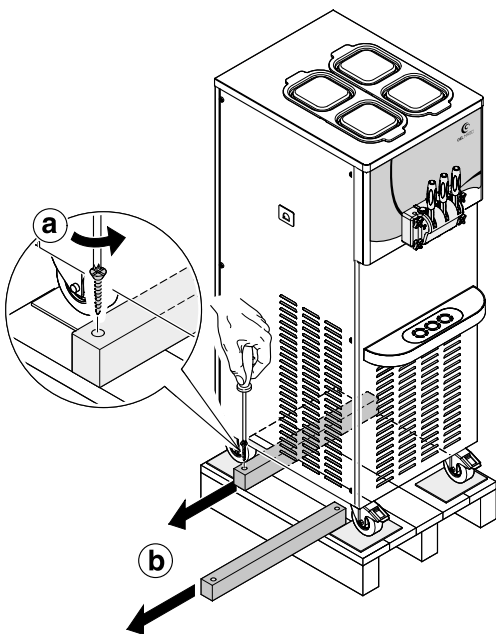

3

TRANSPORTATION

It is compulsory to transport, store and handle the machine in vertical position, according to the instructions you can find on the package.

Always check the TILTWATCH device on the packaging (1), to make sure that the machine is kept upright during transit and movement.

Should the TILTWATCH device warn of incorrect handling, inform the carrier of the same following the instructions provided by the device itself.

The manufacturer cannot be held liable for any damage to the machine during transportation. The recipient is required to check the goods and claim any damages or loss from the carrier responsible for the same.

UNPACKING

Check the area where the machine has to be installed, before removing it from its packaging, making sure that any possible dangers that may arise for the machine itself or the operator are taken into account.

- 1) Make sure that the cardboard box is not damaged.
- 2) Free the machine and extract it by lifting it out of its packaging (both the cardboard box and the cellophane bag) (2).
- 3) Remove the machine from its pallet very carefully (several people are required) (3).



NOTE

For vertical machines, first unscrew the locking blocks, as indicated in the figure.

- 4) Check that the machine is not damaged. If visibly damaged, inform the dealer and the carrier immediately.

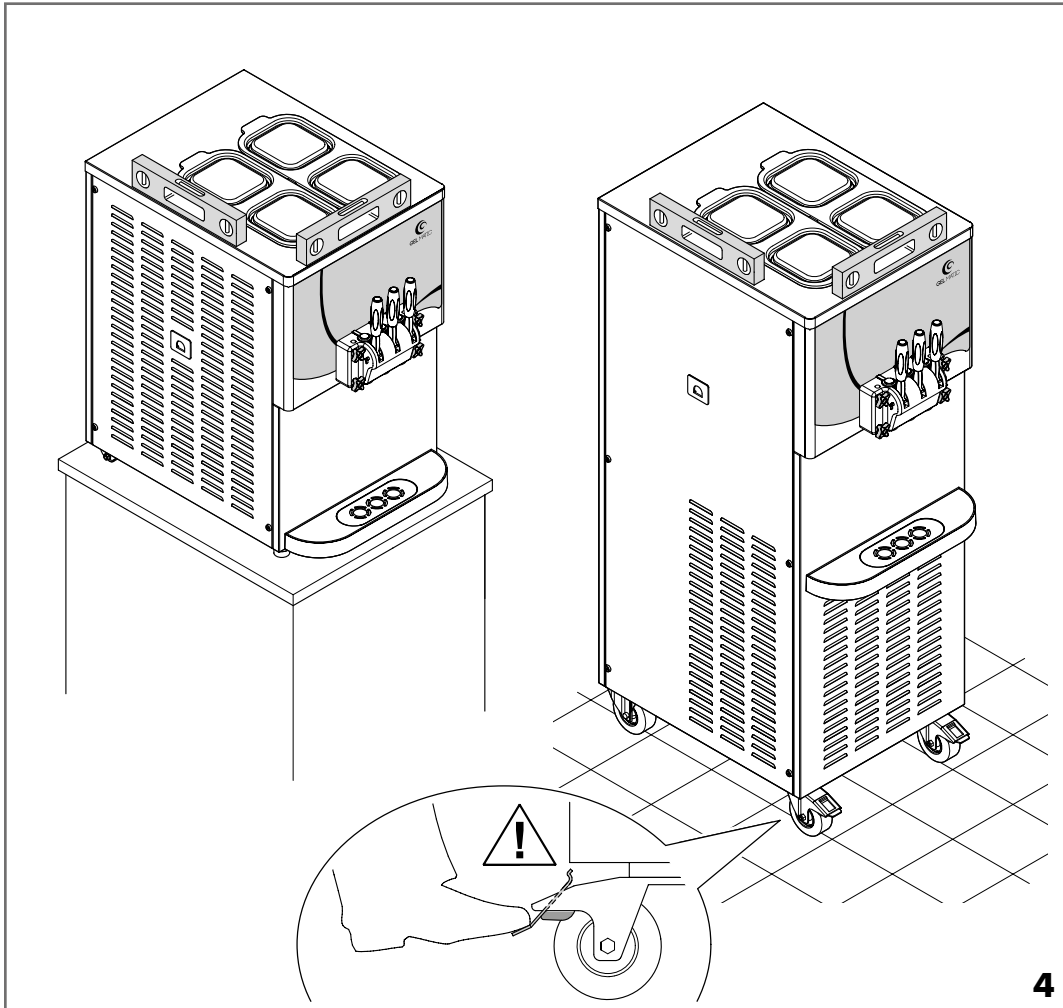

4

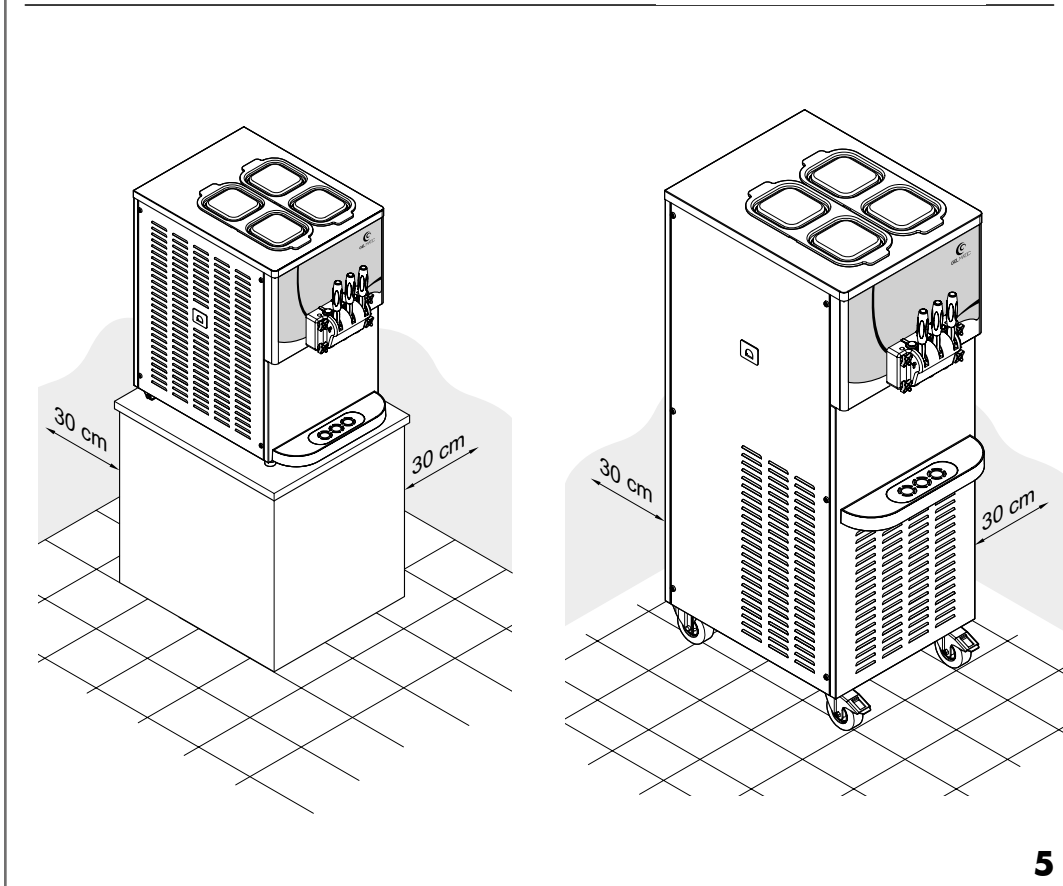

5

INSTALLATION

The machine should be installed by trained technicians, according to the manufacturer's instructions.

The installation includes the following operations:

- positioning
- electrical and water system connection
- testing
- explanation of the operation principles
- start-up and use.

The machine must be installed in accordance with regulations in force.

If you have any questions, please contact your local authorities.

During the installation and maintenance of Gel Matic machines, use great care to ensure that basic safety practices are followed.

POSITIONING

1) Level the machine on the horizontal supporting surface, or on the floor (4). For vertical machines, remember to lock casters.

If, for any reason, the machine must be moved, use extreme care.

To safely move the machine, several people are required.

Failure to observe this warning may cause personal injury or damage to the machine.

2) Position the machine, keeping a minimum clearance of approximately 30 cm from all sides to assure adequate air flow around the machine (5). This will allow an adequate air flow to the condenser. If these distances are not met, the cooling capacity of the machine may be reduced, or permanent damage to the compressor is possible.

Poor ventilation of the machine will affect the operation and performance in terms of production capacity (with possible permanent damage to the compressor).

For water cooled units, this minimum air clearance is not needed.

This machine should NOT be installed in an area close to equipment that can generate jets or sprays of water.

DO NOT use jets or sprays of water to wash or clean the machine.

Infringement of the above directions can generate a risk of electric shock.

3) Do not place any reflective objects in front of the photocell, such as mirrors, glasses or other photocells.

2 INSTRUCTIONS FOR INSTALLATION

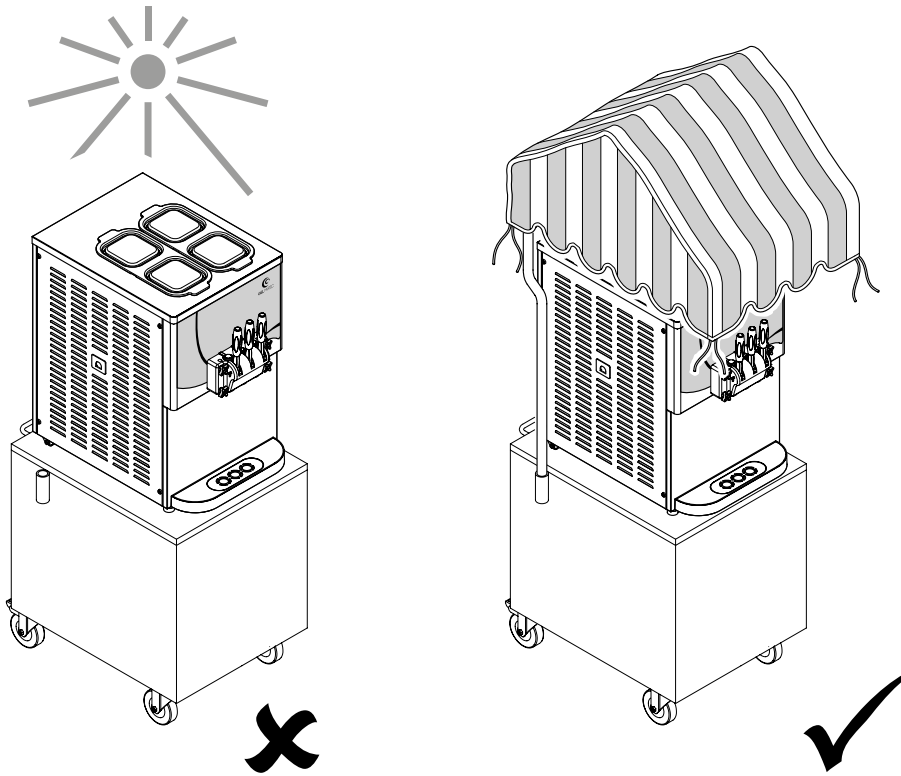

WARNING

This machine shall be properly earthed. Failure to comply with the foregoing may result in injury from electrical shock.



NOTE

To be used only indoors: this unit is designed to work indoors at ambient temperature between 10°C and 30°C (50°F-86°F). The machine still operates properly in environments with high temperature up to 40°C (104°F), albeit with reduced performance. Do not place the machine on a site directly exposed to the sun. If outdoors, protect it with a sunshade or something else (6). Never leave the machine in a room at a temperature above the allowed values.

6

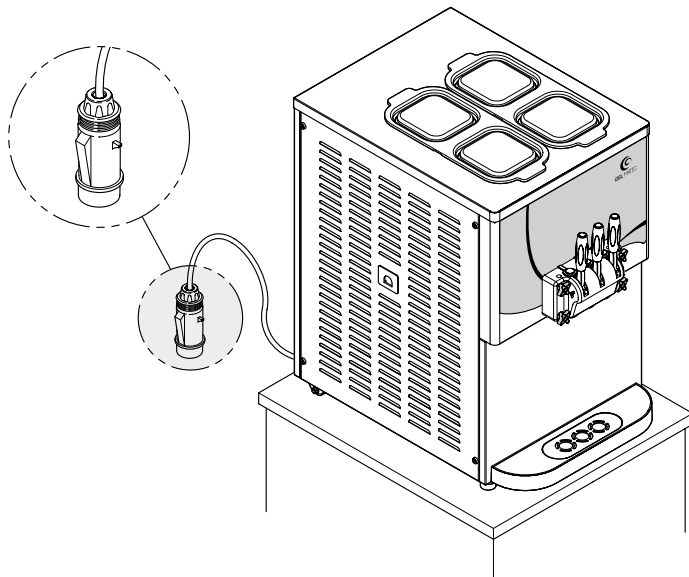

7

ELECTRICAL CONNECTION

All installation and wiring operations should be carried out by trained personnel in accordance with current regulations on safety in the workplace.

Authorized personnel should consult the regulations applicable in the concerned area with regard to industry standards on how to lock / protect the power line.

Before working on the electrical equipment, authorized personnel shall remove any metal objects such as jewellery, watches and rings.

- 1) All electrical connections should be carried out with the power supply off. Failure to follow these instructions can result in injury or death from electrical shock or due to the movement of dangerous parts, or damage the machine and affect its performance.
- 2) To connect the machine to the electricity mains you need to fit an industrial plug (7) of the right value to suit the nominal rating of the machine.

2 INSTRUCTIONS FOR INSTALLATION

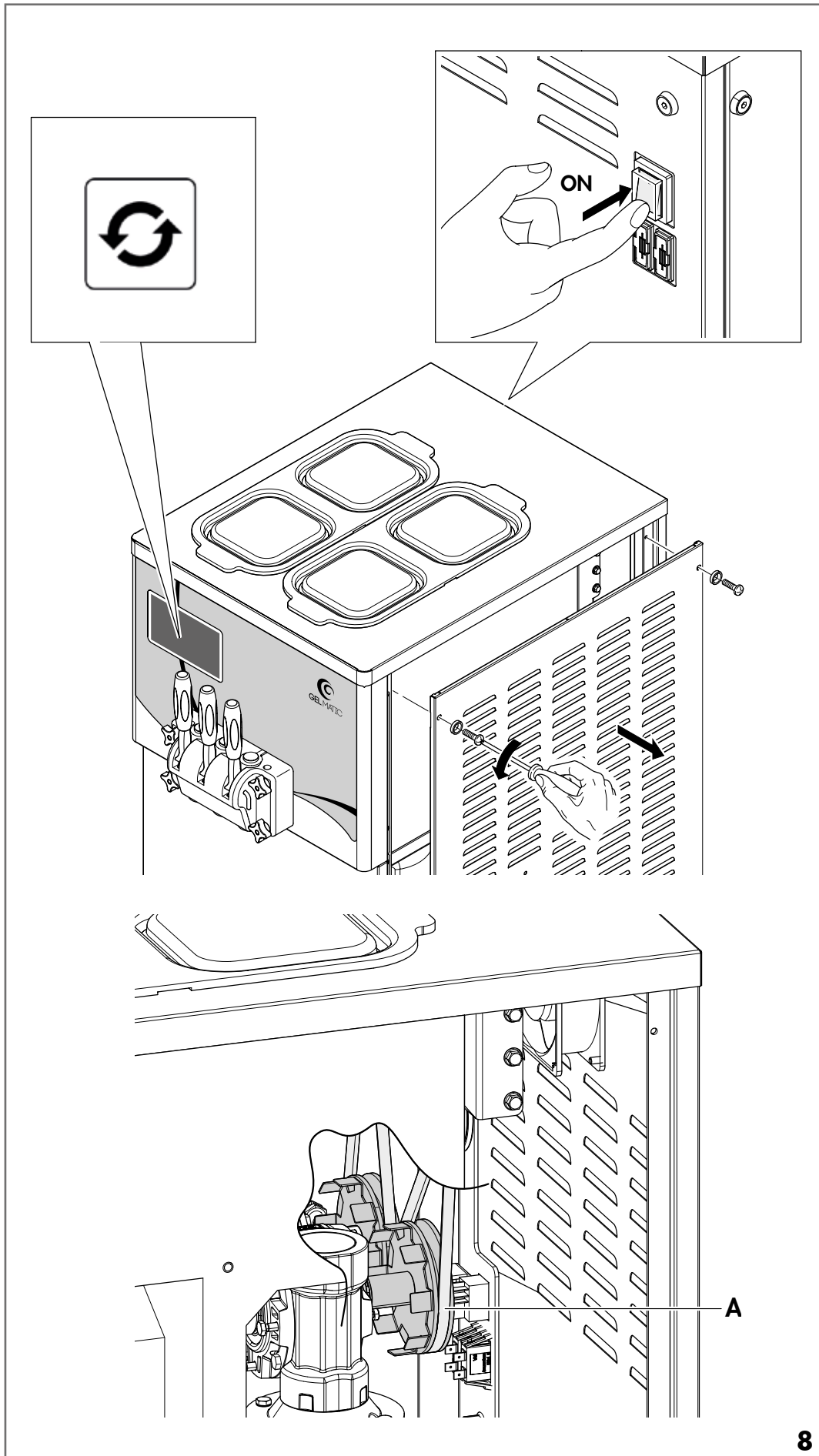

- 3) Check that the power supply, to which the machine is connected, is protected by a magneto-thermal differential circuit breaker designed to absorb the machine electrical power, as indicated on the nameplate of the machine. The circuit breaker should also have a contact separation in all poles that provide full disconnection under overvoltage category III conditions. The earth wire coloured in green and yellow must be connected to good earth grounding. Connect the blue wire to neutral. Never use adaptors, multiple sockets or extension leads (for models with single-phase power, it is not necessary to respect the position of the neutral and phase wire).
- 4) To guarantee machine efficiency and long life, make sure that the power line is the right size.
- 5) The electrical tests are carried out during the ice cream freezing stage, i.e. when both the compressor and the motor are running. Check that the voltage at the terminals of the mains plug do not vary by +/- 10% the nominal rating of the machine (see technical data). Do not use the machine if the available voltage is too low to avoid damaging its components.
- 6) For three-phase units, carry out the following electrical test operations (8):
 - turn the machine on, using the switch placed on the rear panel
 - open movable panel on the right-hand side of the machine
 - set the machine to WASH mode
 - looking at the machine from the front, check that the gear wheel (A), turns clockwise for models BC 250 PM, BV 200 PM; or anti-clockwise for models MV 254 PM, HV 254 PM. If this is not the case, disassemble the power cable plug and invert two supply phases (it is not necessary to check the direction of rotation for the models with single-phase power supply).
- 7) If the supply cord is damaged, it must be replaced by the manufacturer, a Gel Matic technician or similarly qualified technicians in order to avoid any hazard.

8

2 INSTRUCTIONS FOR INSTALLATION

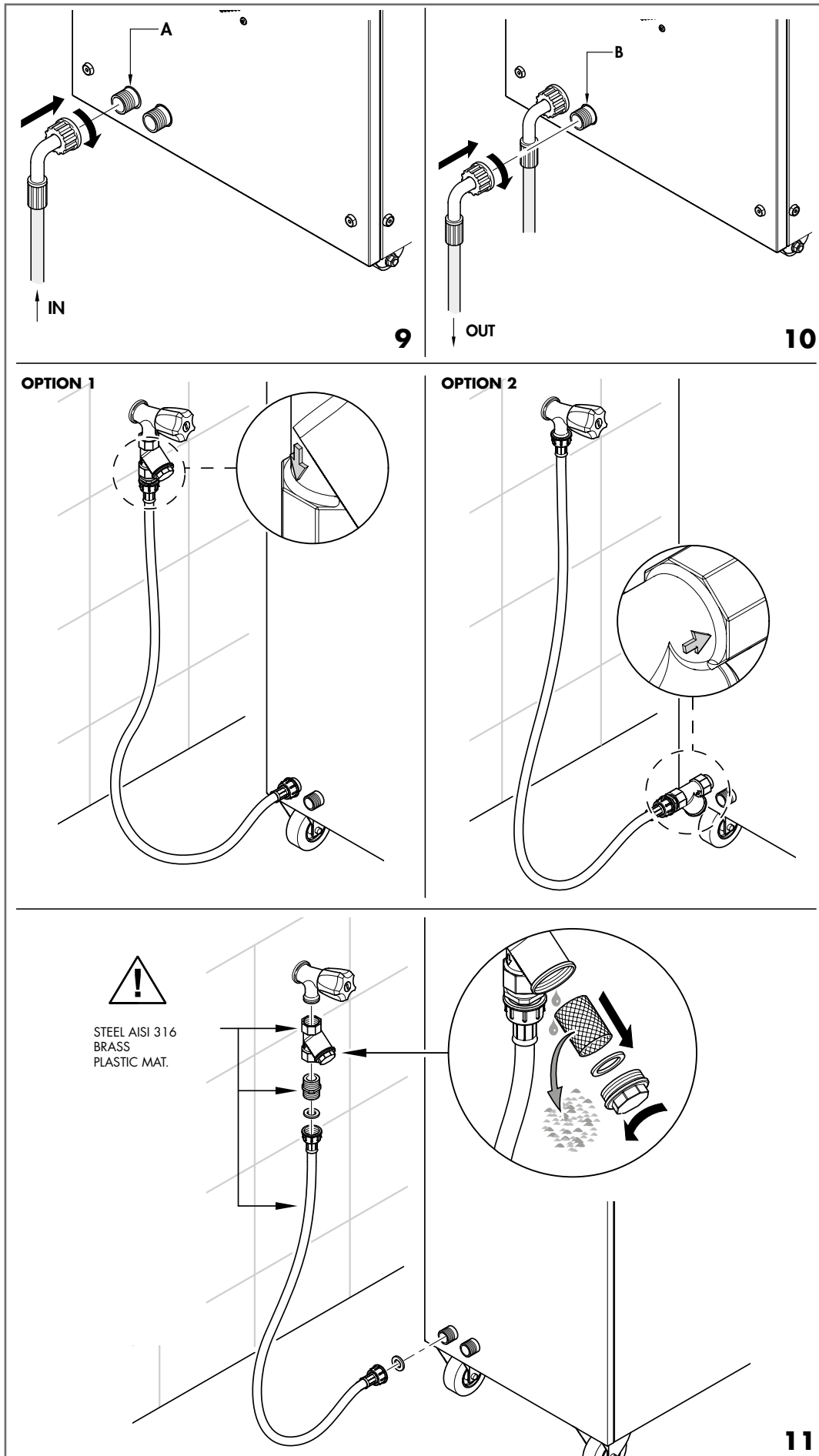

NOTE
The following steps must be performed by a qualified technician.



WARNING
Do not remove side panels without unplugging the power supply.

Permanent wiring

Permanent wiring may be employed if required by local codes. Instructions for conversion to permanent wiring are as follows:

1. Be sure the machine is electrically disconnected.
2. Remove the appropriate panel and locate the electrical connection where the supply cord is connected.
3. Remove the connection tabs and the strain relief hook. Remove the factory-installed cord.
4. Route incoming permanent wiring through the hole and a conduit in order to avoid any folding.
5. Install the field-wiring terminals and connect to them the power supply leads. Connect two power supply leads. Attach ground (earth) wire to the grounding lug inside.
6. Be sure the unit is properly grounded before applying power.



FOLLOW YOUR LOCAL ELECTRICAL CODES!



WATER CONNECTION

For machines equipped with water cooling, provide the connection to a cooling tower or to the water network according to the following procedure:

- 1) Connect the mains pipe to fitting **A** (inlet) (9). The water supply must have a pressure between 0.1 MPa and 0.8 MPa (1-8 bar) and a flow rate adequate to dissipate the heat of condensation. The inlet water temperature should not exceed 20°C (68 °F).
- 2) Connect the drain pipe to fitting **B** (outlet) (10). The outlet water temperature is approx. 40°C (104°F).

We recommend installing an easily inspectable drain tap to check the quantity and temperature of the waste water.

2 INSTRUCTIONS FOR INSTALLATION

GEL-MATIC ITALIA SRL VIA G. GALILEI, 10 - 24050 - ORIO AL SERIO - (BG) - ITALY

MODEL	BV 250 PM		
ELECTRIC POWER	3 Ø	380-415 V~	50 Hz
POWER	2,8 kW	7 A	IP 23



REFRIGERATION GAS: R404A Q.TY: 1000g

Insulation blowing gas: polyurethane + P-MDI

SERIAL NUMBER
XXXXXX

12

It is necessary to fit the purification filter supplied to the water inlet (11), in order to prevent impurities, scaling or other materials from compromising the tightness of the pressure valve or damaging the condensing unit. This filter should be cleaned and replaced at regular intervals.

If the water is especially "hard" (i.e. high calcareous content), fit a water softener to prevent scaling of the condenser.

We recommend using braided rubber hoses suitable for pressures of at least 1000 KPa (10 bar), with an inside diameter of 10 mm. We recommend using new pipes; do not fit used ones.

WARNING
 The installation of a non-return valve on the connection of incoming water is required. Please refer to local regulations, in order to define the appropriate connection.

REFRIGERANT
 As for protection of the environment, Gel Matic is proud to use only environmentally friendly HFC refrigerants. The HFC refrigerant used in this machine is R404A. This refrigerant is generally considered non toxic and non flammable, with an ozone depletion potential of 0. Nevertheless, all gases under pressure are potential hazards and must be handled with care.

If the refrigerant comes into contact with the skin, can cause severe damage. Protect your eyes and skin. In case of burns, rinse immediately with cold water. If the burns are severe, apply ice packs and contact a doctor immediately.

TECHNICAL DATA
 All the technical data for this machine are indicated on the adhesive nameplate on the machine (12). The data of the example shown in the figure are to be considered for illustrative purposes only.

INTRODUCTION

Dear Customer, thank you for choosing a quality product such as ours that we're sure will meet your expectations. Please read this instruction manual carefully before using your soft ice cream machine. The machine has been designed exclusively for the production of soft ice cream and frozen yogurt. Any use of this machine other than its intended use is to be considered improper, dangerous and not recommended.

Carefully read the warnings contained in this manual before installing and operating the unit.

The manufacturer cannot be held liable for direct or consequential damage to people or property due to the use of the machine other than its intended purpose, in particular:

- non observance of the intended use
- use of the machine by untrained operators
- maintenance, adjustment and repair of the machine by untrained personnel
- tampering with the machine, which is not only dangerous, but will invalidate the machine warranty
- the removal of or tampering with safety devices
- the use of non original spare parts, especially for those components having safety functions.

The information contained in this manual is private property and cannot be reproduced, totally or partially, without prior authorization by the manufacturer.

This manual should be kept in an easily accessible place for future reference.

This manual does not cover all issues in detail; for further information, contact your dealer.

WARRANTY

Unless otherwise indicated upon purchase of the machine, this machine and all its components are covered by a 12 month guarantee, provided the fault is recognized by the manufacturer.

Any damage or loss arising from improper use of this machine is not covered by the machine warranty.

The guarantee is subject to the following:

- final test, carried out by qualified technician or Gel Matic technician;
- prompt sending by the Purchaser of the warranty certificate accompanying each machine (in a sealed envelope and by means of registered letter with recorded delivery within 15 days from the delivery of the machine);
- use of original Gel Matic spare parts.

Failure to comply with the prescriptions of this manual will make the guarantee void.

SAFETY INFORMATION

The manufacturer cannot be held liable for consequent damage to people, things or animals, resulting from the failure to comply with safety regulations and warnings contained in the supplied documentation.

This appliance is intended to be used in household and similar applications such as:

- staff kitchen areas in shops, offices and other working environments;
- farm houses and by clients in hotels, motels and other residential type environments;
- bed and breakfast type environments;
- catering and similar non-retail applications.

The appliance is only to be installed in locations where it can be overseen by trained personnel.

The access to the service area is restricted to persons having knowledge and practical experience of the appliance, in particular as far as safety and hygiene are concerned.

NOISE

For both machines with air and water condensation, the noise level (A-weighted equivalent continuous sound pressure level in the workplace is less than 70dB (A).

DANGEROUS AREAS AND RESIDUAL RISKS

Careful analysis of risks carried out by the manufacturer has eliminated most risks relating to both possible and reasonably foreseeable operating conditions of the machine. Some of the intervention procedures on the machine, described in this manual, can cause residual risks for the operator. Residual risks can be eliminated by carefully following the procedures contained in this manual. In particular it is necessary to pay attention to install and power the machine in accordance with current regulations on safety in the workplace.

INTENDED USE

The machine must only be used for the production of soft ice cream and frozen yogurt, as indicated in the introduction to this manual and within the limits given below:

- Power supply voltage $\pm 10\%$
- Minimum air temperature 5°C (41°F)
- Max air temperature 40°C (104°F)
- Minimum water temperature 5°C (41°F)
- Max water temperature 20°C (68°F)
- Minimum water pressure 0.1 MPa (1 bar)
- Maximum water pressure 0.8 MPa (8 bar)
- Air relative humidity max 85%

Do not store explosive substances such as aerosol cans with a flammable propellant in this appliance.

CLEANING SOLUTION

In order to ensure a proper cleaning procedure, Gel Matic recommends using STERA SHEEN Green Label product diluted as follows: 56.7 g/2 oz of STERA SHEEN Green Label in 7.57 litres / 2 gal of warm water.

SANITIZING SOLUTION

In order to ensure a proper sanitizing procedure, Gel Matic recommends using STERA SHEEN Green Label product diluted as follows: 56.7 g/2 oz of STERA SHEEN Green Label in 7.57 litres / 2 gal of warm water.



NOTE

The cleaning/sanitizing solution cannot stay in contact with metal and plastic parts for more than 15 minutes. Otherwise, the surfaces may corrode.

In case of use of different cleaners/sanitizers than the recommended one, consult the manufacturer to ensure their suitability for use.

5 IDENTIFICATION OF COMPONENTS

Machine exploded view

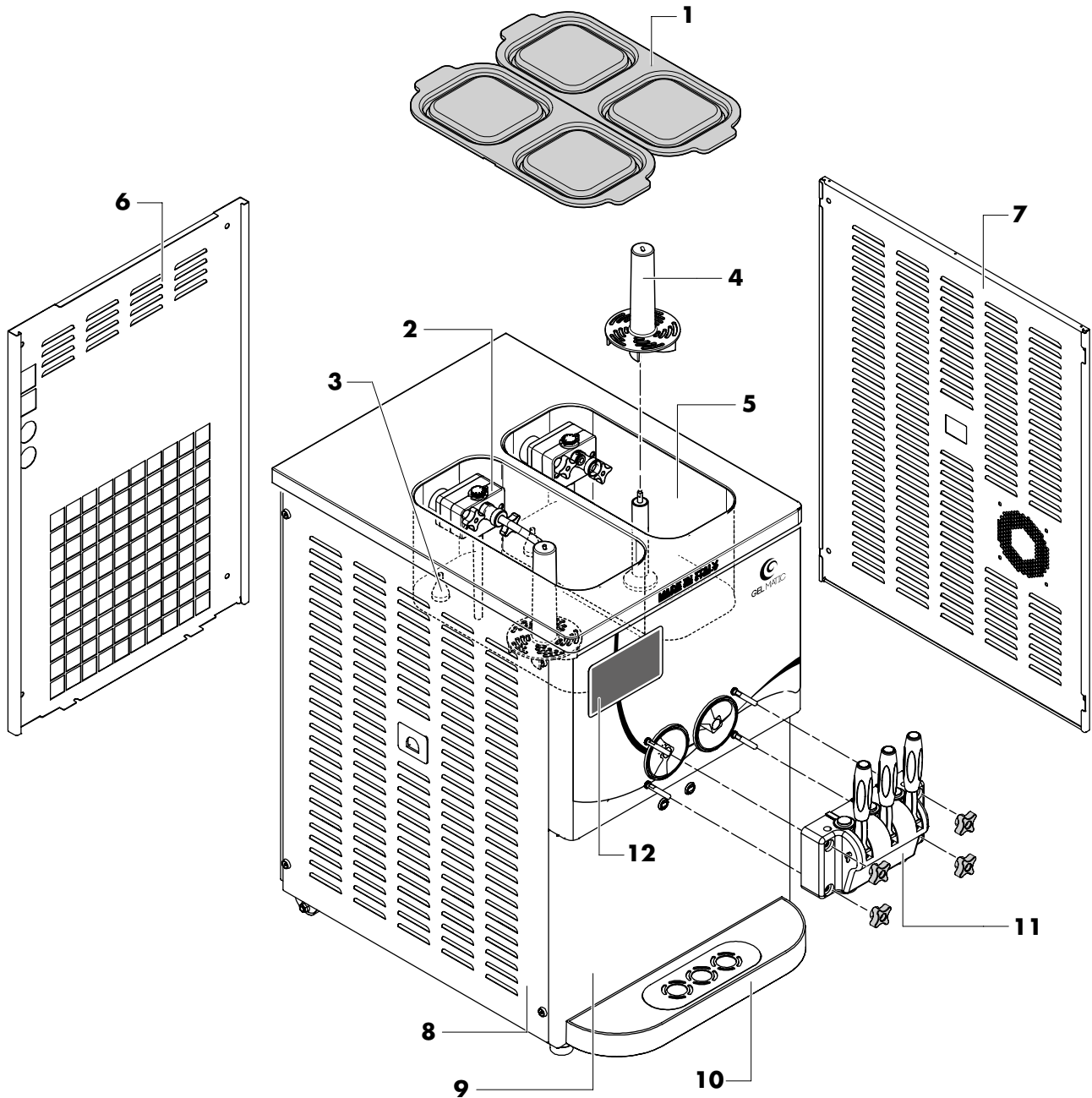

1	CoperHopper lid	7	RH side panel
2	Pump unit	8	LH side panel
3	Level sensor	9	Front panel
4	Mixer	10	Drip tray
5	Storage hopper	11	Dispensing door
6	Rear panel	12	"In.Co.Di.S." Touch screen

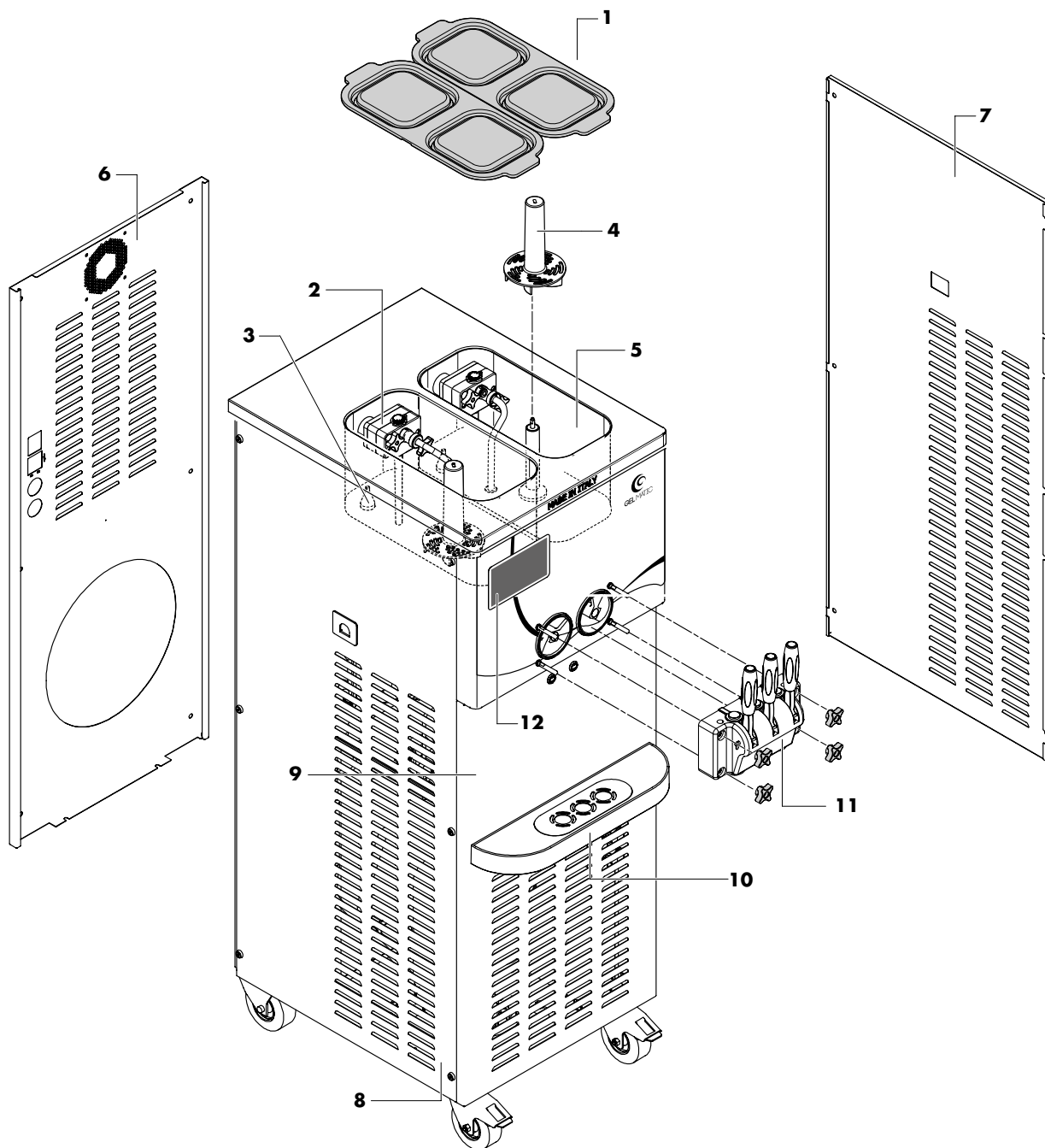
BV 250 PM
Machine exploded view

1	Hopper lid	7	RH side panel
2	Pump unit	8	LH side panel
3	Level sensor	9	Front panel
4	Mixer	10	Drip tray
5	Storage hopper	11	Dispensing door
6	Rear panel	12	"In.Co.Di.S." Touch screen

Dispensing door exploded view

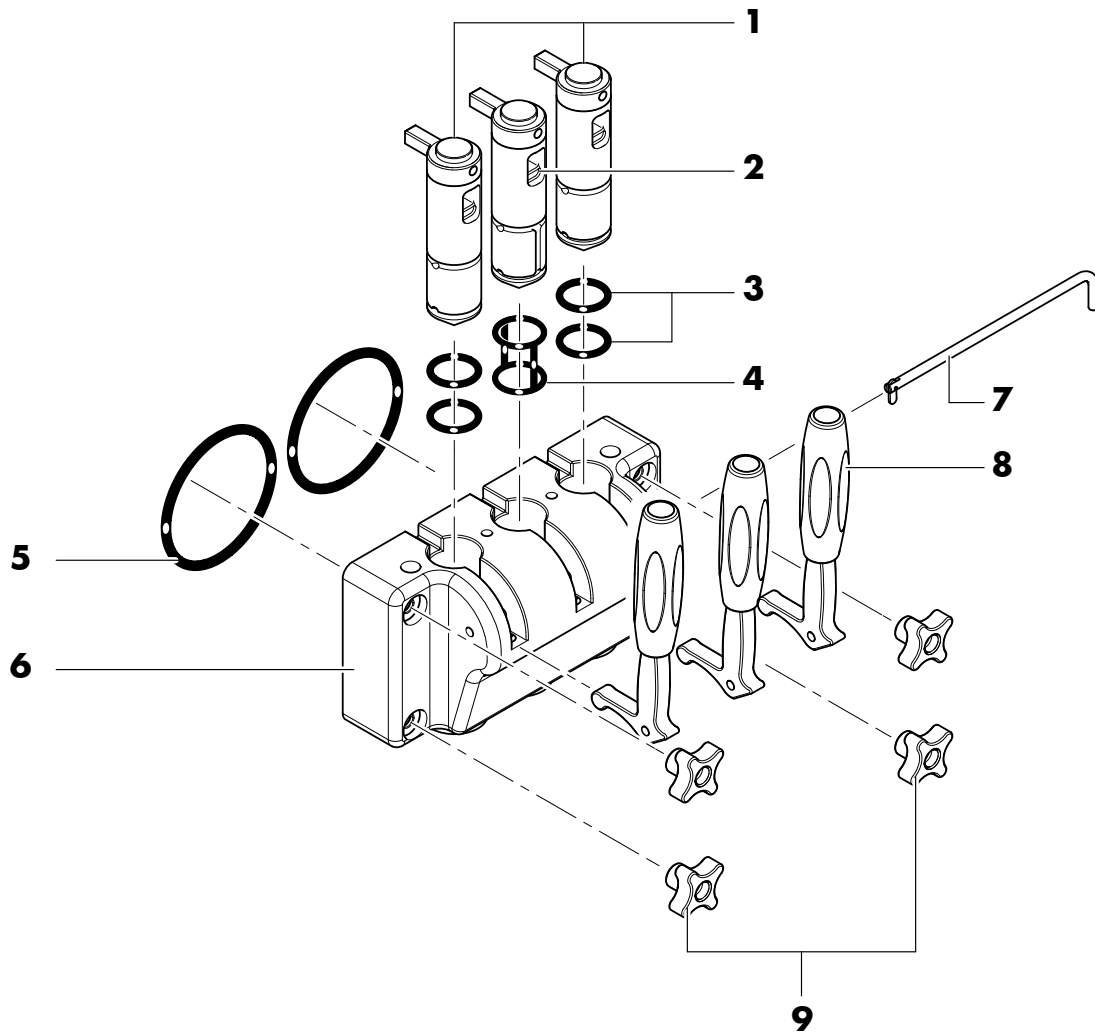

1	Lateral piston
2	Central piston
3	O-ring gasket for lateral piston
4	Cage O-ring
5	Dispensing door gasket
6	Dispensing door
7	Lever fastening pin
8	Dispensing lever
9	Fastening knobs



SP2 beater exploded view

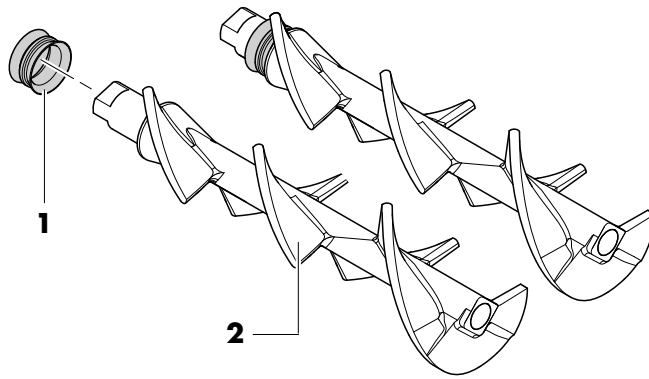

1	Beater gasket
2	Beater

LS1 beater exploded view

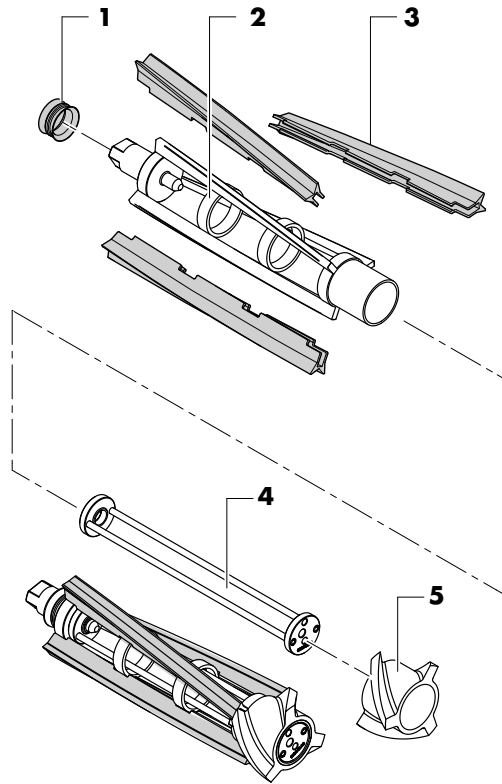

SF1 beater exploded view

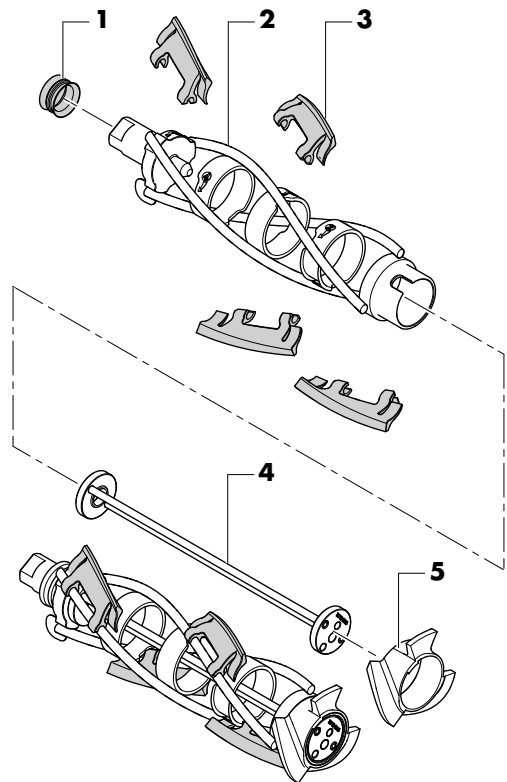

1	Beater gasket
2	Beater body
3	Beater scrapers
4	Counter rotating shaft
5	Beater worm

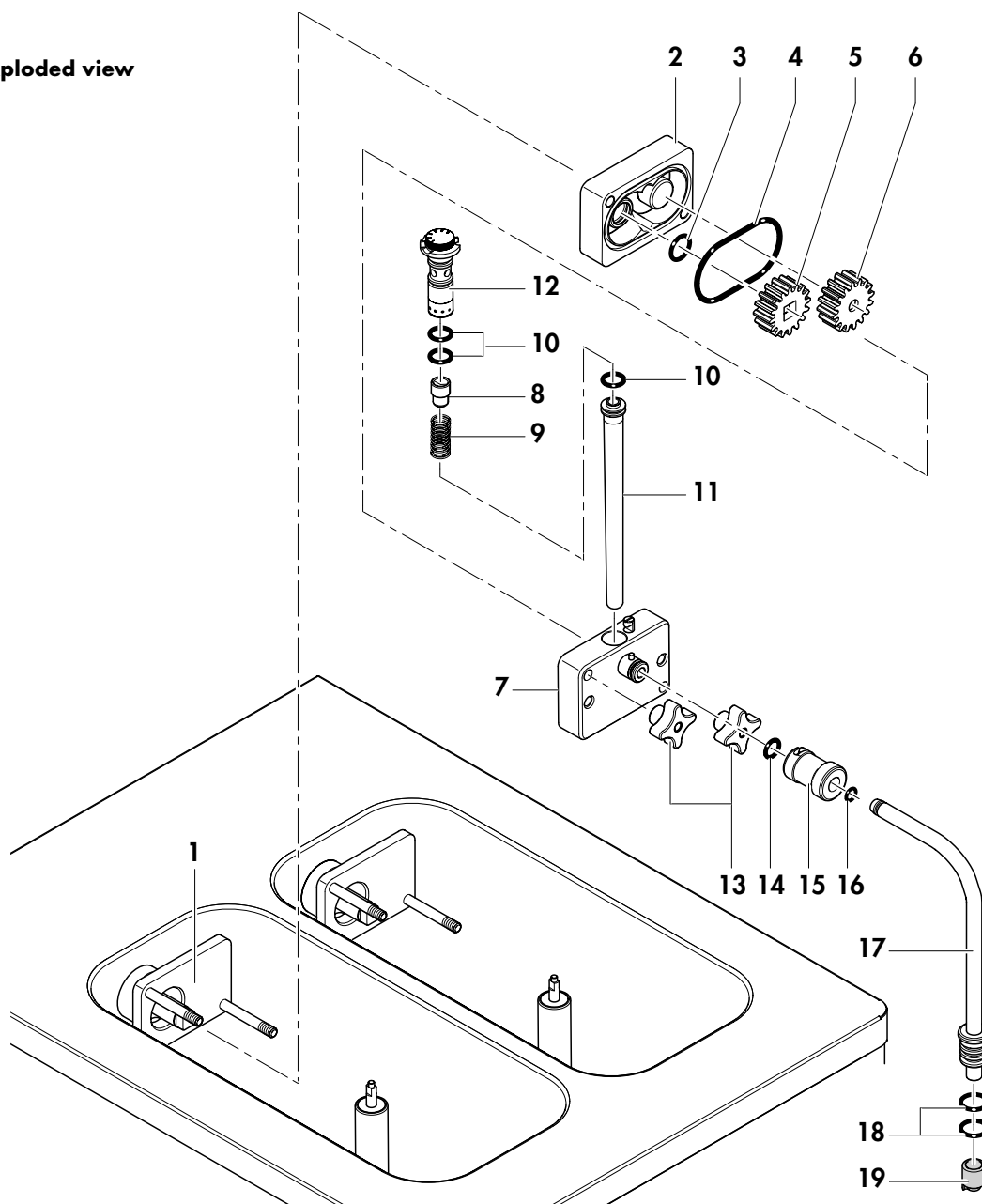
Pump exploded view

1	Pump connection	11	Suction pipe
2	Pump body	12	Overrun regulator
3	O-ring	13	Fastening knobs
4	Pump body gasket	14	O-ring gasket
5	Drive gear	15	Bayonet joint
6	Idle gear	16	O-ring gasket
7	Pump cover	17	Compression pipe
8	By-pass valve	18	O-ring gaskets
9	By-pass spring	19	Non-return valve
10	O-ring gasket		

5 IDENTIFICATION OF COMPONENTS

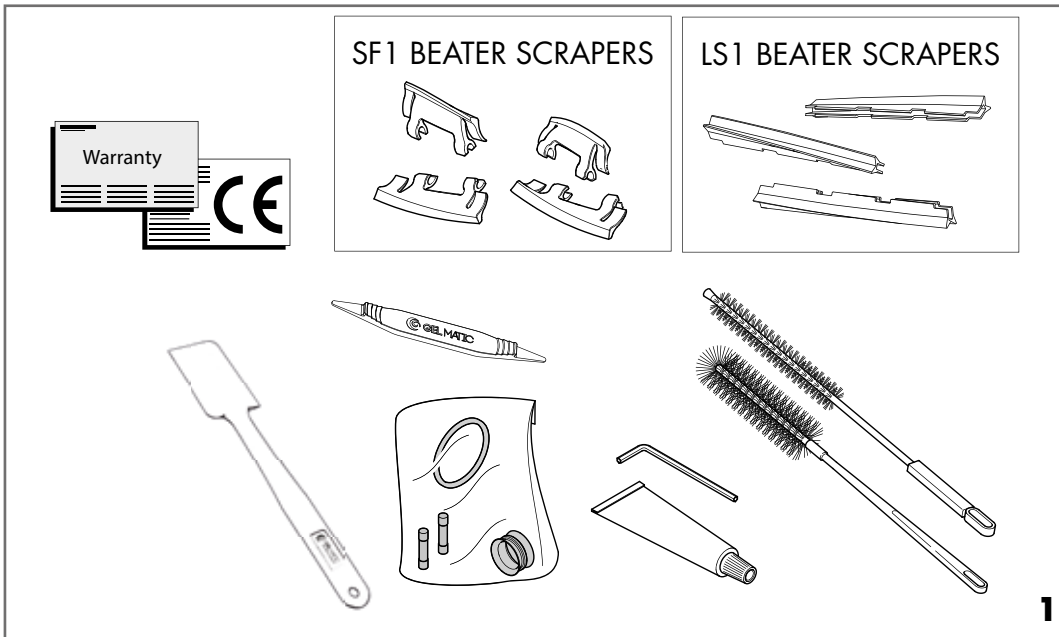

1

MACHINE EQUIPMENT

Each machine is supplied with the following documentation and parts (1):

- warranty certificate
- declaration of conformity CE
- set of useful spare parts (complete set of gaskets for dispensing door, beater, pump and protection fuses)
- scraping blades
- Allen wrench for the adjustment of the output speed of the ice cream
- small cleaning brushes
- Gel Matic spatula
- food grease tube for lubrication of gaskets and plastic components.
- tool for O-ring removal.

"IN.CO.DI.S." TOUCH SCREEN SYMBOLS DEFINITION (2)

The advanced In.Co.Di.S. system, with LCD touch screen technology allows you to easily communicate with the machine at any operating step.



NOTE

The In.Co.Di.S. system, with touch screen technology, is a very delicate device, so it is necessary to follow the instructions below for its proper use:

1) To select the desired function, press the corresponding icon with your finger for at least 1 second. The function is enabled when the button has a blue background.

Press and hold it for a few seconds to view relevant Help On Board, which contains further information about the icon selected.

2) Do not select two icons at the same time

3) Press the symbol ←, to close the displayed window and go back to the previous one.

4) Press the symbol ✓ to confirm the amended value.

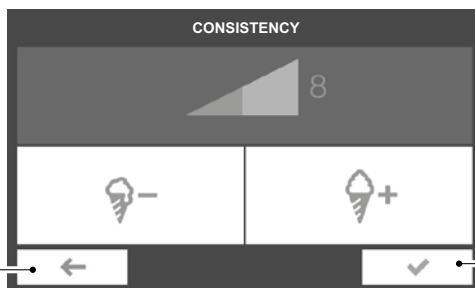
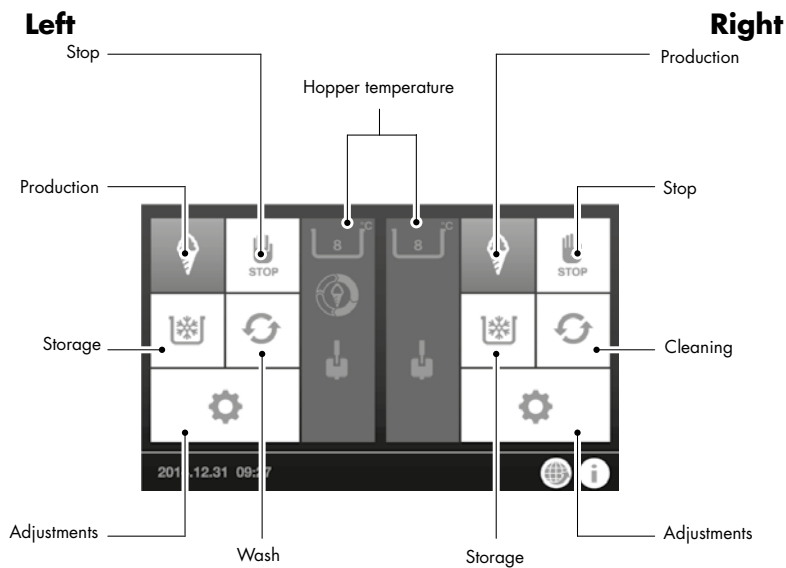

Back (without confirmation)

Confirmation

2

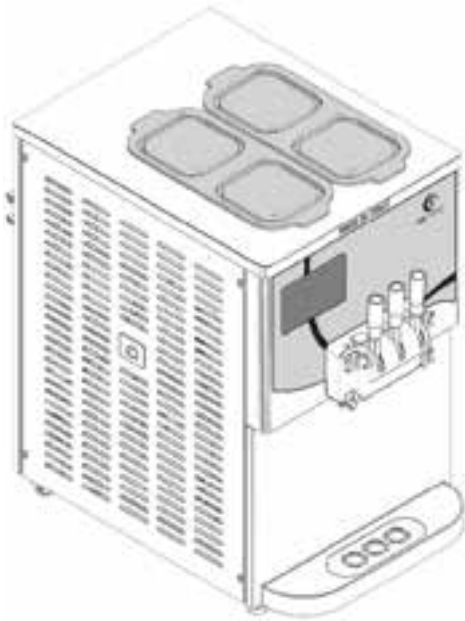
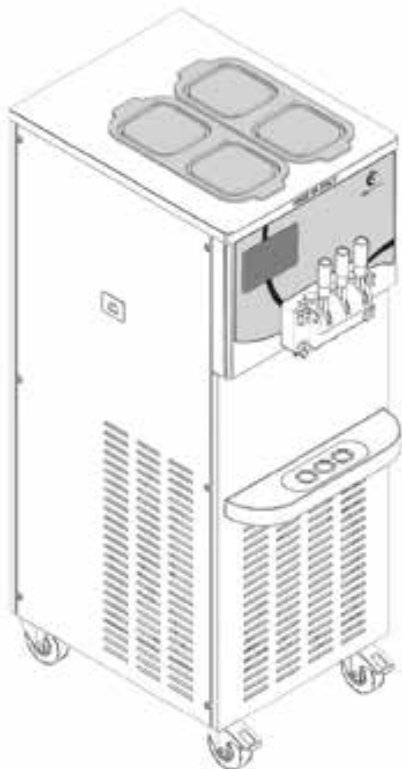
**BC 250 PM****BV 250 PM**

The BC 250 PM is a two-flavour + mix countertop machine with pressurizing gear pump, for the production of express gelato, soft serve and frozen yogurt.

The machine is equipped with two storage hoppers, with real loading capacity of 10 litres and 1.7-litre freezing cylinder.

The BV 250 PM is a two-flavour + mix vertical machine with pressurizing gear pump, for the production of express gelato, soft serve and frozen yogurt.

The machine is equipped with two storage hoppers, with real loading capacity of 10 litres and 1.7-litre freezing cylinder.

The following instructions are for the morning, when you enter the shop and find the various components removed the previous evening and dry, after cleaning.

If, instead, you have to disassemble the machine for the first time or you need directions to get to this point, see paragraph "Disassembly of the various components" in this manual.

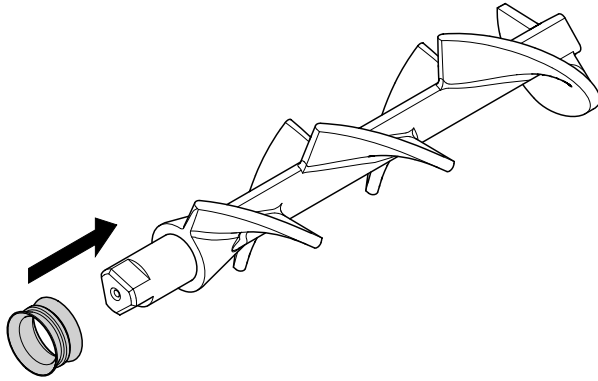

Step 1

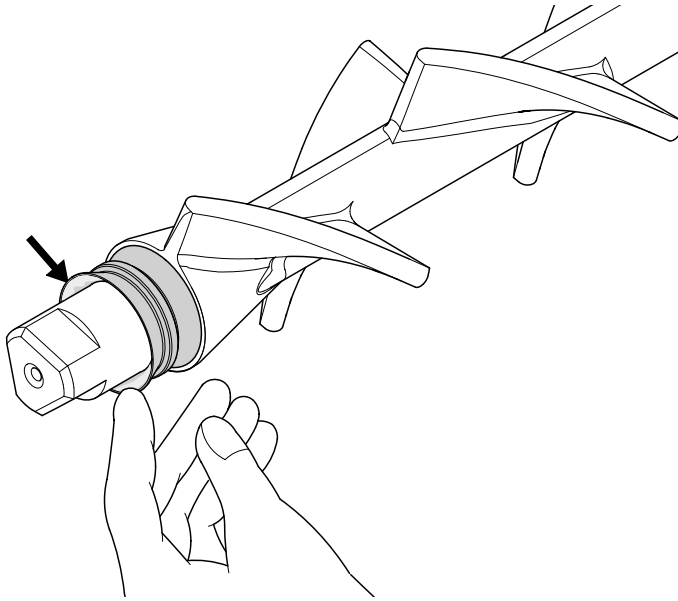

Step 2

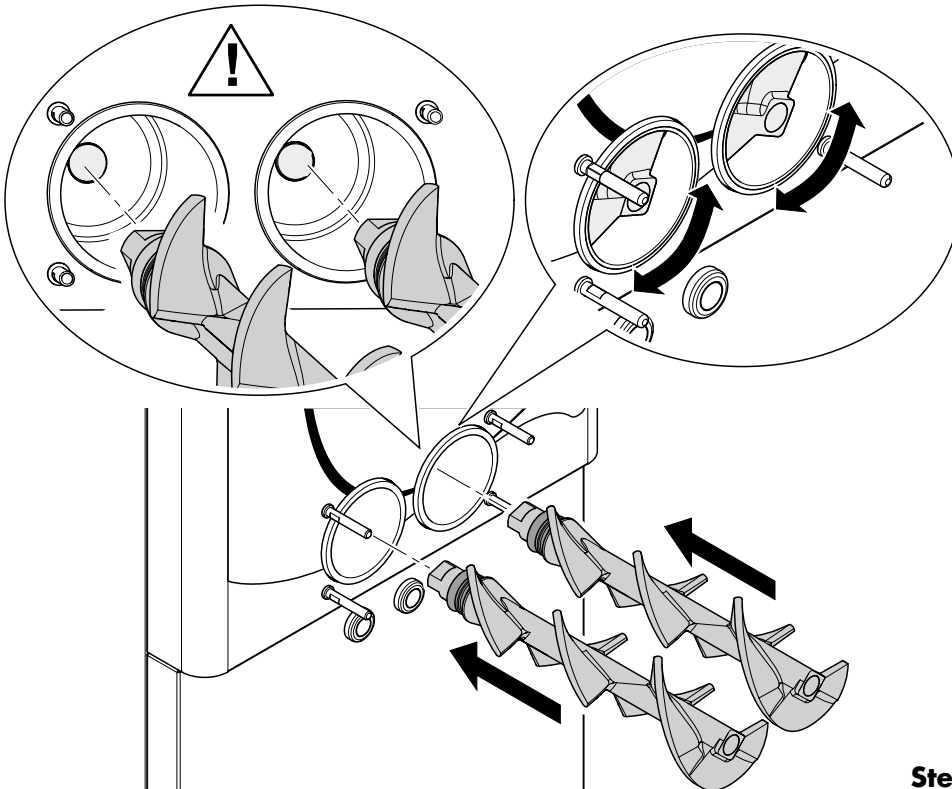

Step 3

ASSEMBLY OF THE VARIOUS COMPONENTS

WARNING
Make sure the power switch is off (OFF).
 Failure to do so may cause serious personal injury due to moving parts.

Assembly of the SP2 beater

Step 1

Install the gasket of the beater.

Step 2

Lubricate the final part of the gasket, which will be in contact with the cylinder, as indicated in the figure.



NOTE

Check the gasket for signs of wear, cracks or cuts.

Step 3

Insert the beater in the freezing cylinder; align the hole at the bottom of the beater, so as to couple it to the drive shaft.



NOTE

The gasket shall be replaced every 6 months.

Gently rotate the beater to make sure that it is firmly seated on the drive shaft.

Once in position, the beater must not protrude out of the freezing cylinder.



NOTE

Repeat steps 1÷3 for the other beater.



NOTE

The difference between the edge of the cylinder and that of the beater must not exceed 3 mm.

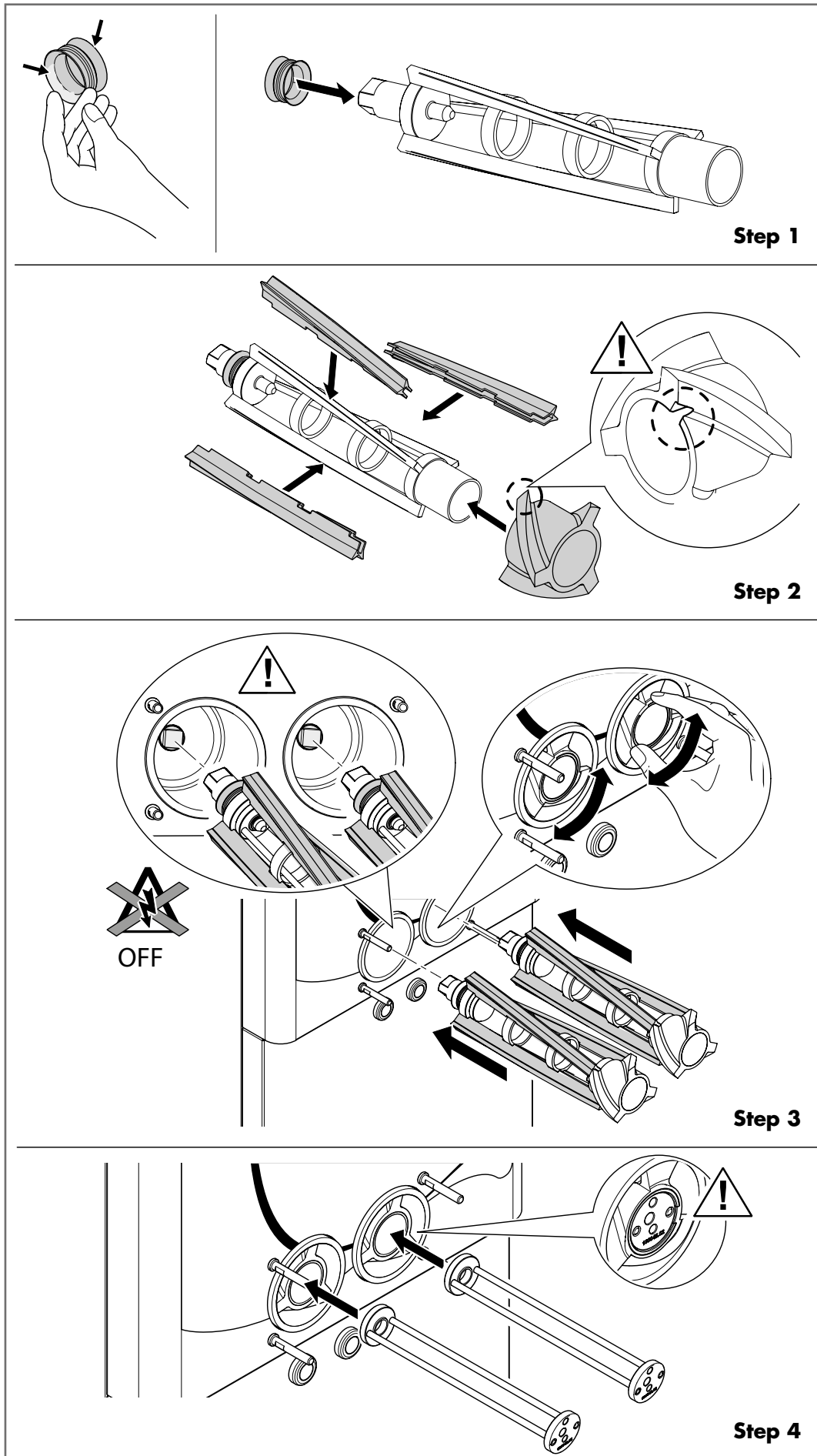

Assembly of the LS1 beater

Step 1

Lubricate the final part of the gasket, which will be in contact with the cylinder, as indicated in the figure.
Install the gasket of the beater.



NOTE

Check the gasket for signs of wear, cracks or cuts.

Step 2

Mount the 3 scrapers on the beater body.

Insert the worm and rotate slightly so that the slot is in correspondence of the gauge on the beater body.

Step 3

Insert the beater in the freezing cylinder; align the hole at the bottom of the beater, so as to couple it to the drive shaft.



NOTE

The gasket shall be replaced every 6 months.

Gently rotate the beater to make sure that it is firmly seated on the drive shaft.

Once in position, the worm must not protrude from the freezing cylinder.



NOTE

The difference between the edge of the cylinder and that of the beater must not exceed 3 mm.

Step 4

Place the counter rotating shaft, making sure that the holes are positioned as shown in the figure.



NOTE

Repeat steps 1÷4 for the other beater.

6 INSTRUCTIONS FOR USE

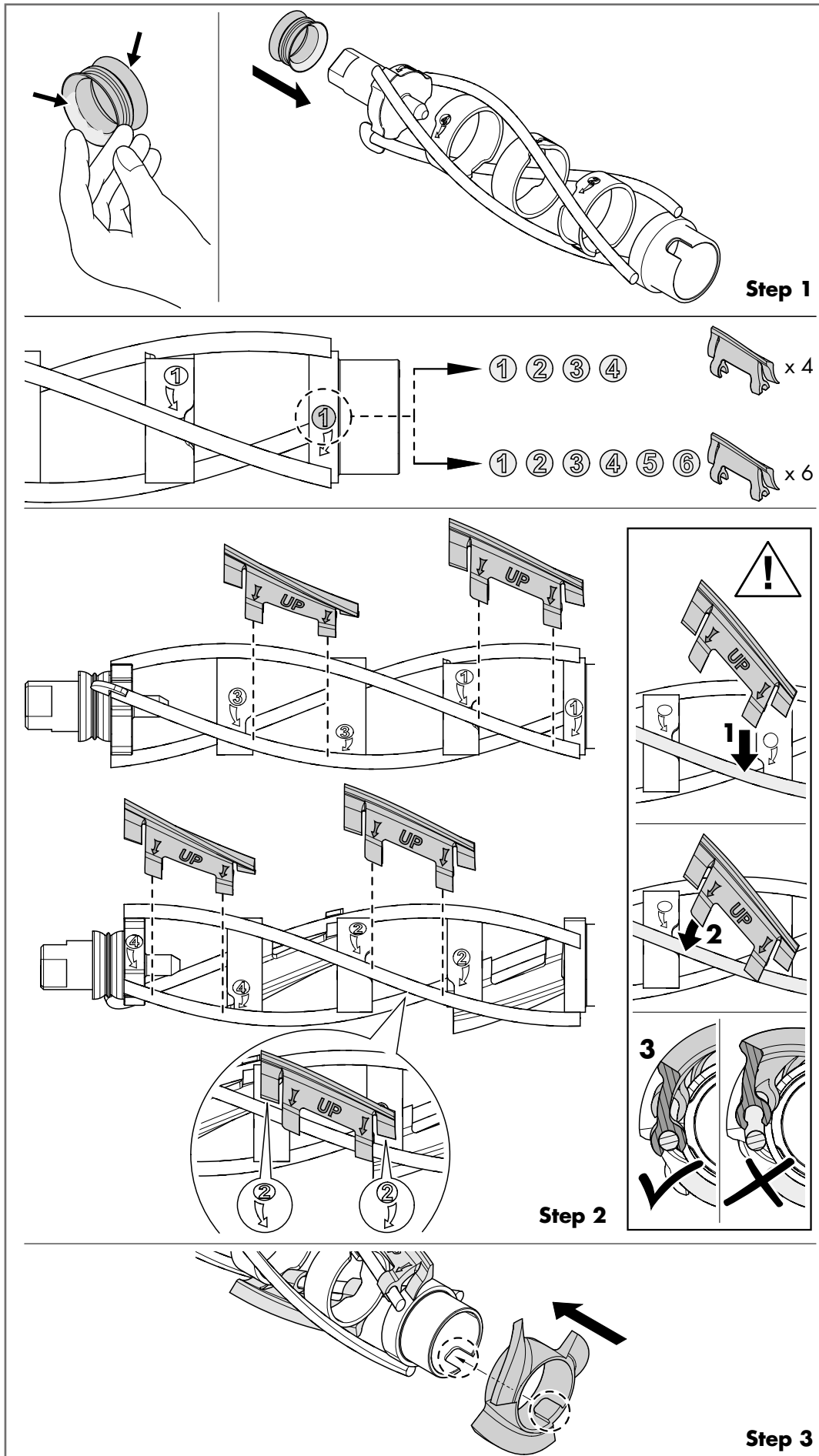

Assembly of the SF1 beater

Step 1

Lubricate the final part of the gasket, which will be in contact with the cylinder, as indicated in the figure.

Install the gasket of the beater.



NOTE

Check the gasket for signs of wear, cracks or cuts.

Step 2

Mount the 4 scrapers (BC 250 PM - BV 250 PM - BV 261 PM - MV 254 PM), the 6 scrapers (HV 254 PM), on the beater body, following the sequence indicated by the numbers printed on the beater body. Make sure the word "UP" printed on the scraper is pointing upwards.



NOTE

For proper assembly, tilt the scraper and hook the clamps one by one.

Make sure both clamps are fitted on the steel pin.

Step 3

Insert the worm and rotate slightly so that the slot is in correspondence of the gauge on the beater body.

Step 2

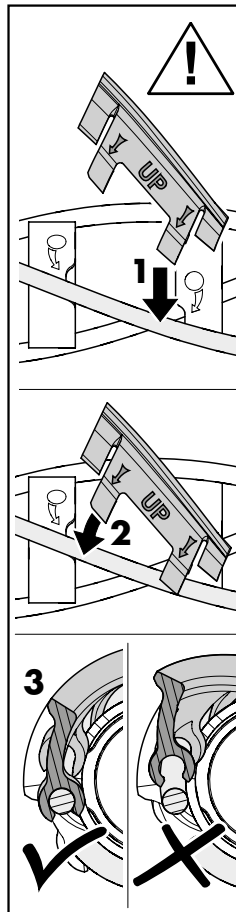

Step 3

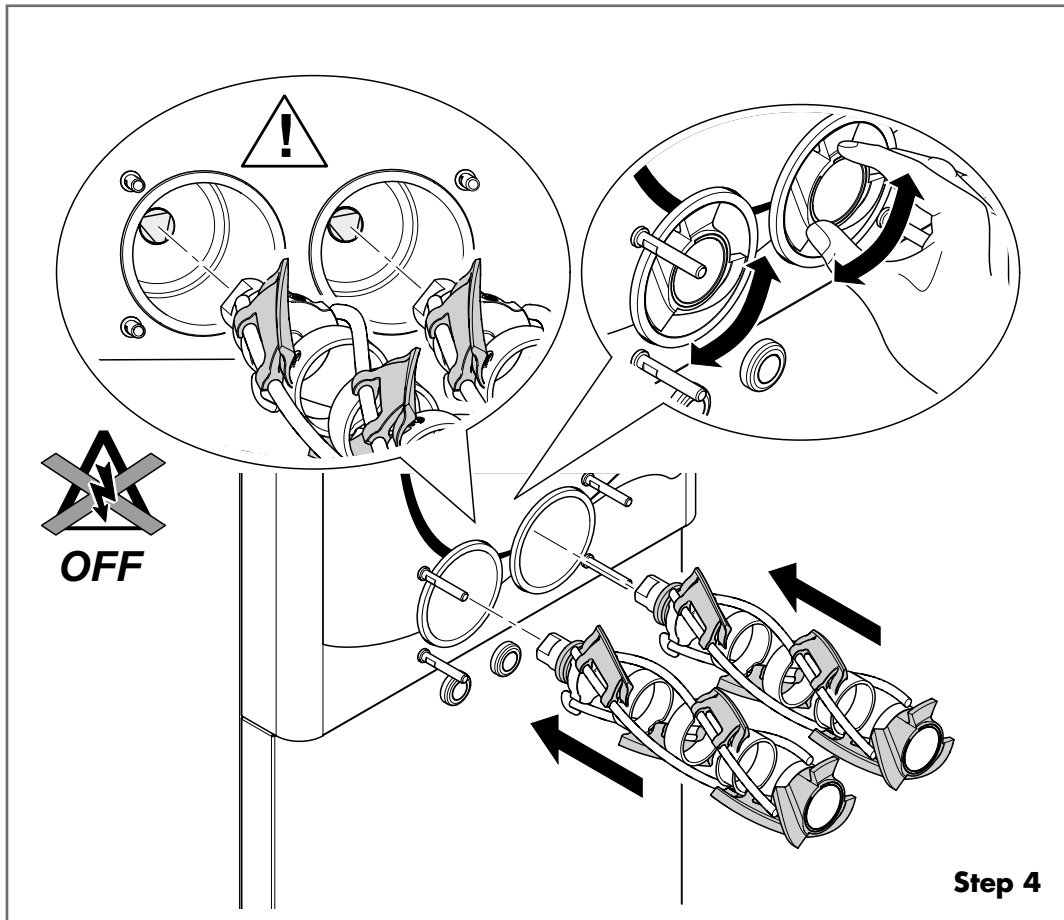

Step 4

Step 4

Insert the beater in the freezing cylinder; align the hole at the bottom of the beater, so as to couple it to the drive shaft.



NOTE

The gasket shall be replaced every 6 months.

Gently rotate the beater to make sure that it is firmly seated on the drive shaft.

Once in position, the worm must not protrude from the freezing cylinder.



NOTE

The difference between the edge of the cylinder and that of the beater must not exceed 3 mm.

Step 5

Place the counter rotating shaft, making sure that the holes are positioned as shown in the figure.



NOTE

Repeat steps 1÷5 for the other beater.

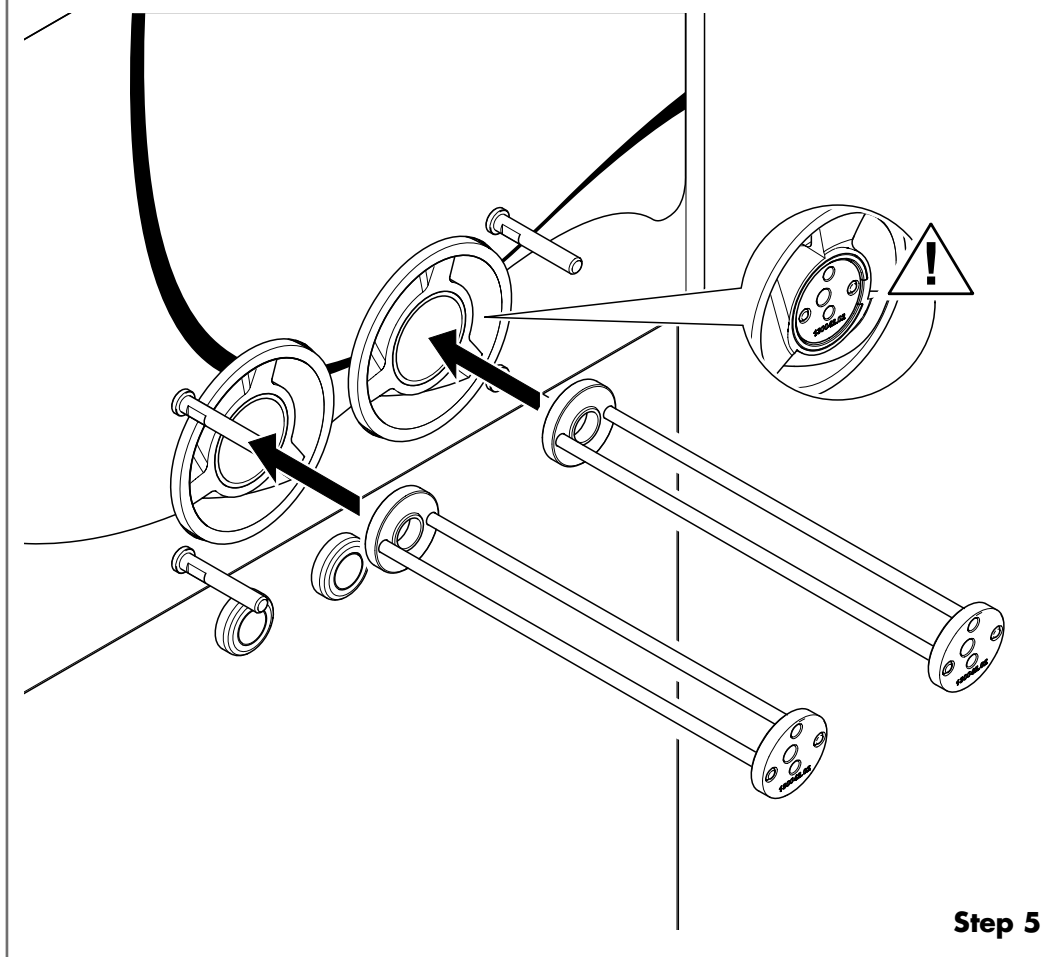

Step 5

6 INSTRUCTIONS FOR USE

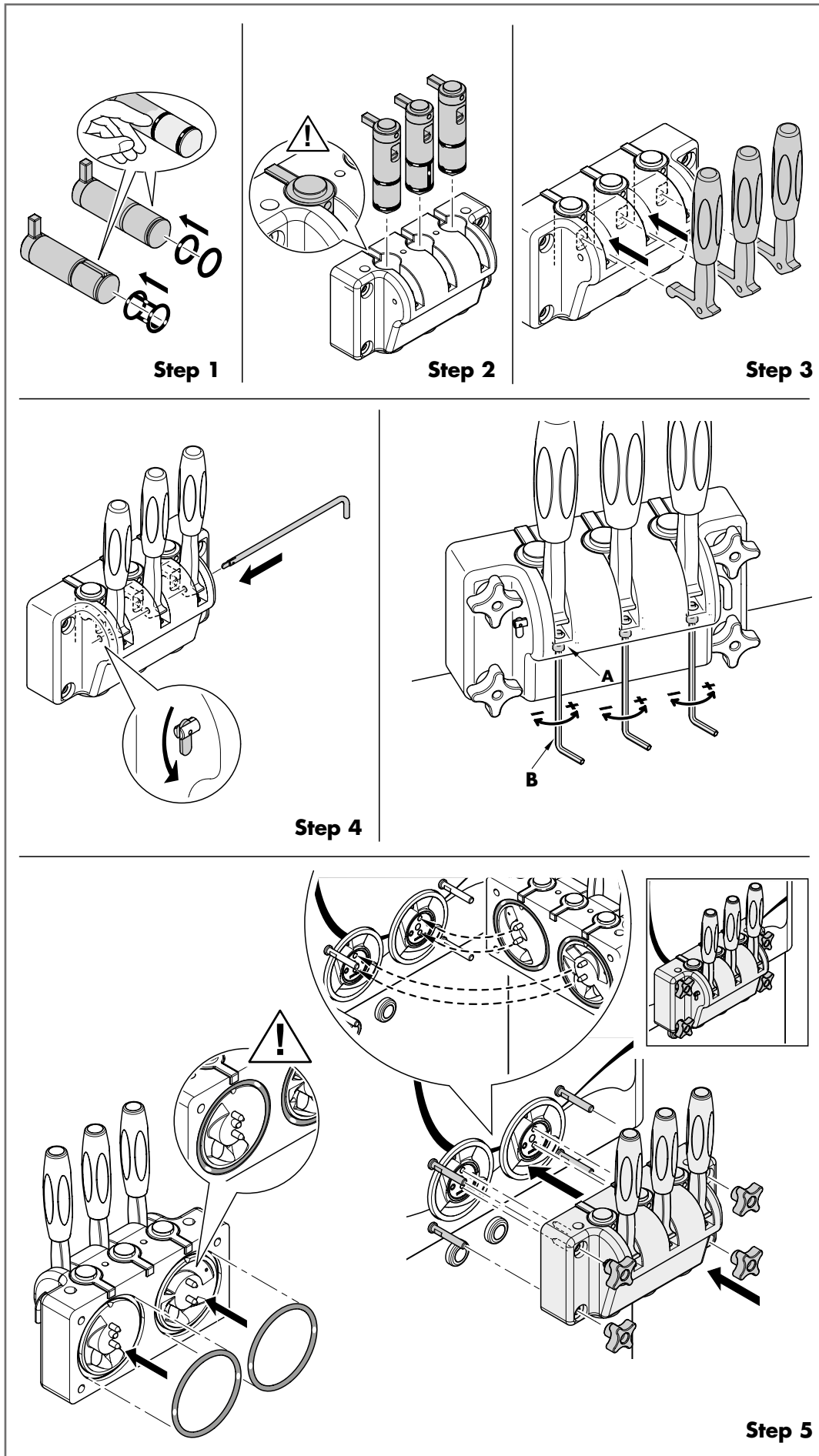

Assembly of the dispensing door

Step 1
Install the O-rings in their seats on the pistons and lubricate them.

NOTE
For the central piston, install the cage gasket.

Step 2
Place the pistons on the dispensing door through the openings at the top, carefully pushing through.

Step 3
Insert the levers into the openings of the pistons.

Step 4
Insert the lever fastening pin.

NOTE
The lever is adjustable, in order to control the serving, ensuring the optimum consistency and reduce costs.
The lever is normally adjusted to deliver a serving of 150g to 200g of product (from 5.3 oz to 7oz) in about 12 seconds.
To reduce the rate of delivery, turn the adjusting screw "A" (3) counter-clockwise, using the appropriate Allen key "B" (3) supplied
Turn clockwise to increase the rate of delivery.

Step 5
To assemble the dispensing door, first insert the gaskets in place on the back of it.
Make the dispensing door slide on the machine studs, so that the pins at the back of the door match with the holes on the counter rotating shaft.
Fit the fastening knobs.

6 INSTRUCTIONS FOR USE

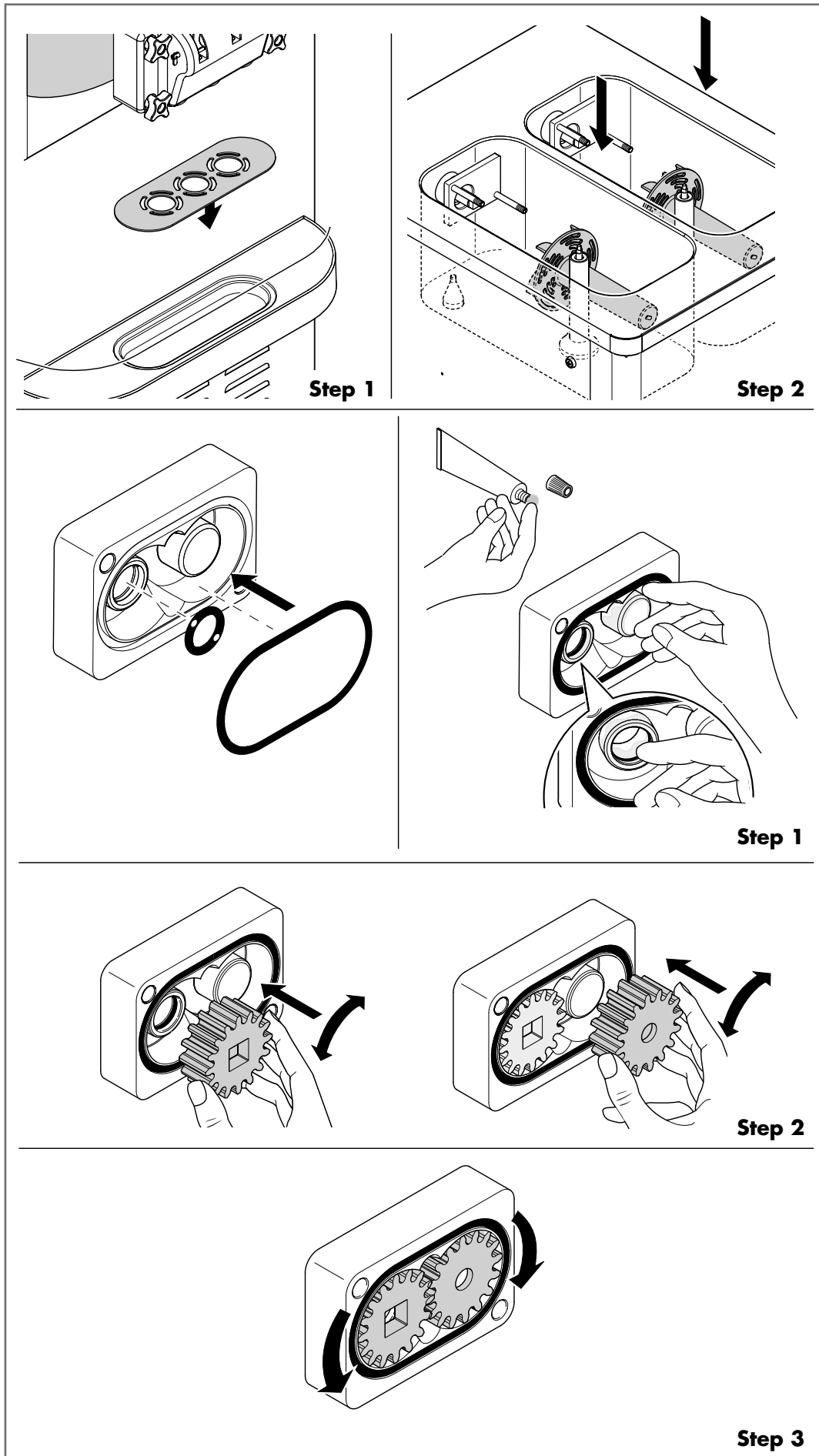

Assembly of the drip-tray and the mixer

Step 1
Mount the drip tray below the dispensing door.

Step 2
For machines with a mixer: place the mixers on the bottom of the hoppers.

Assembly of the pump

Step 1
Install the O-rings in the pump body and lubricate the pins of the gears inside the pump body. As for the gaskets, lubricate only the one inside the drive gear pin, as shown in the figure.

Step 2
Mount the gears on the pump body.

Step 3
Rotate the gears, making sure they are not locked, but free to rotate.

NOTE
Repeat steps 1÷3 for the other pump.

WARNING
Pay full attention to any impact or fall that may damage the gears. To avoid ruin the machine and cause malfunctioning, NEVER use the machine with damaged gears.

6 INSTRUCTIONS FOR USE

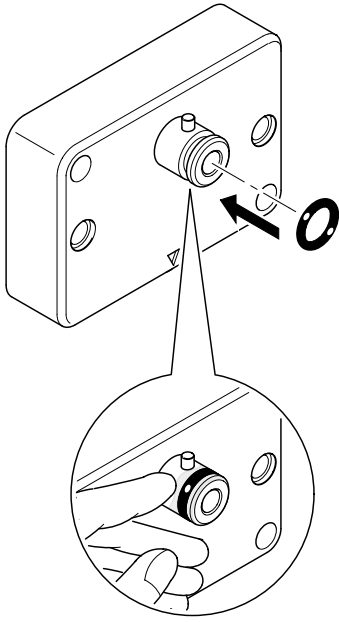

Step 4

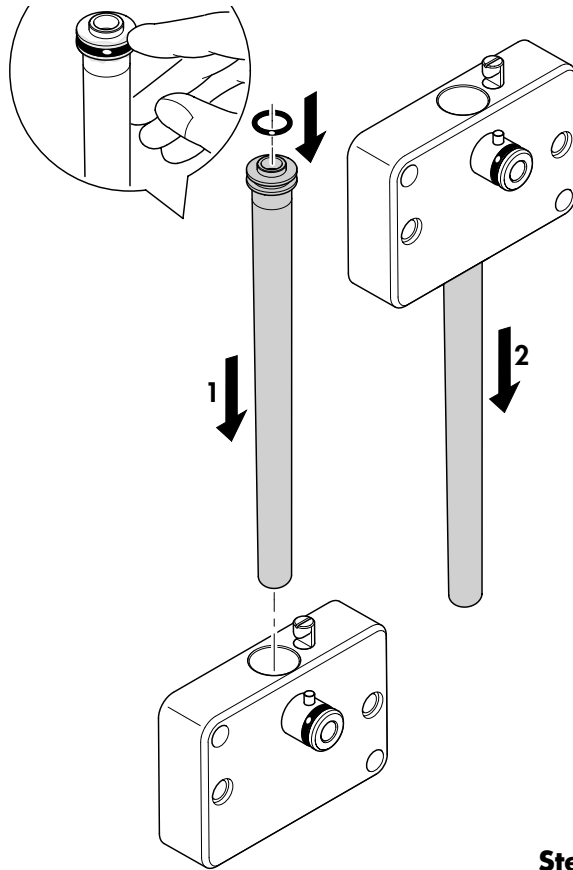

Step 5

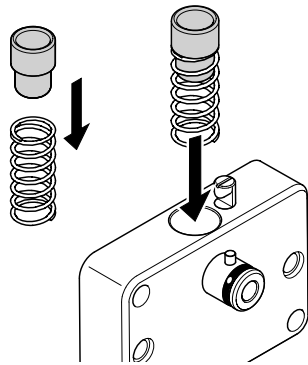

Step 6

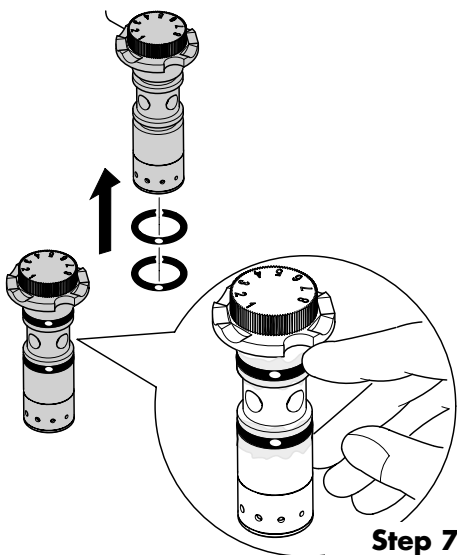

Step 7

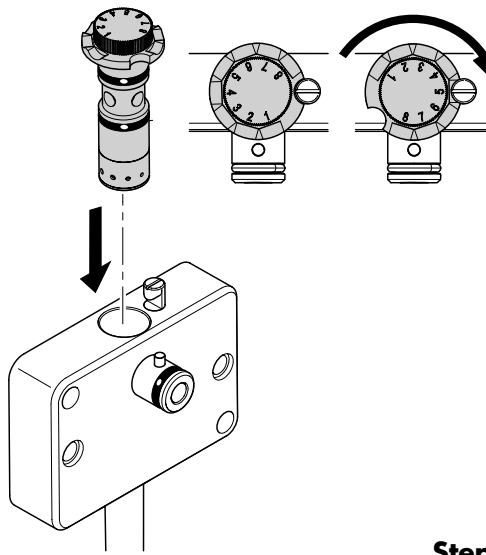

Step 8

Step 4
Install the O-ring on the pump cover connection and lubricate it.

Step 5
Install the O-ring on the suction pipe and lubricate it.
Insert the suction pipe into the pump cover from the top and fit it in place by pulling it down.

Step 6
Insert the by-pass valve in the spring.
Insert both the valve and the spring in the pump cover.

Step 7
Install the two O-rings in the overrun regulator and lubricate them.

Step 8
Insert the complete overrun regulator in the pump cover, slightly rotating it.

Match the regulator slot with the pump cover pin, as shown in the figure.

Press and rotate, locking it in one of the eight positions available (see paragraph "Overrun Adjustment").

6 INSTRUCTIONS FOR USE

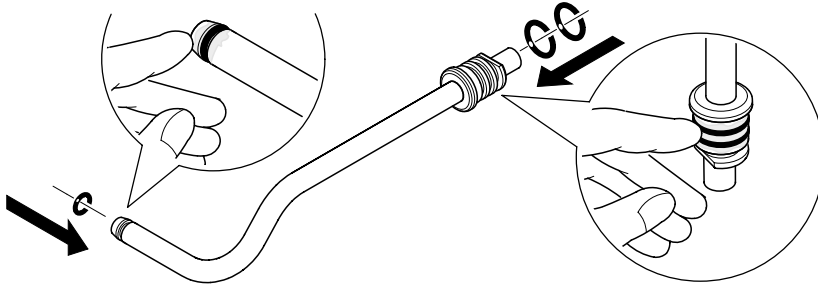

Step 9

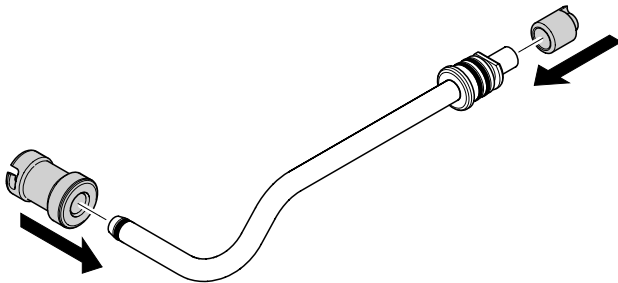

Step 10

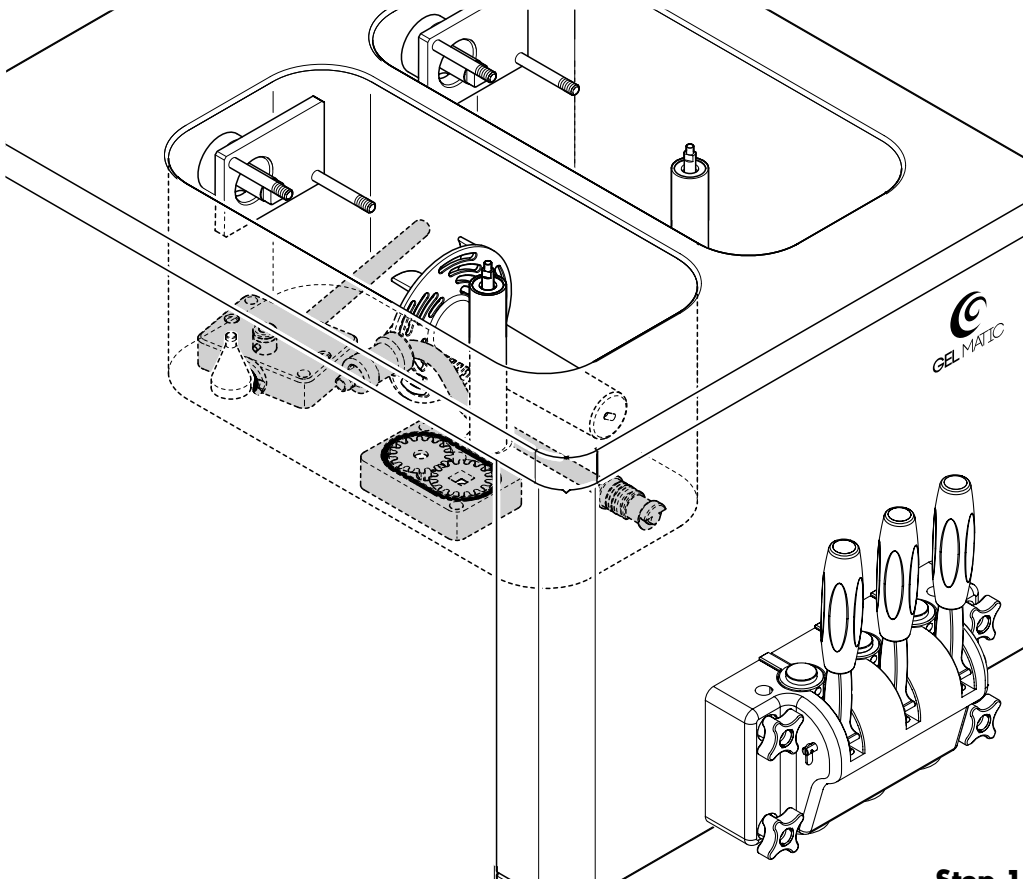

Step 11

Step 9
Install the O-rings on the compression pipe and lubricate them.

Step 10
Install the non-return valve, without lubricating, and insert the bayonet joint.

Step 11
Place the pump components on the hopper bottom for the sanitization, as shown in the figure:

- pump body complete with gears;
- compression pipe;
- pump cover complete with suction pipe.



NOTE
Repeat steps 4÷11 for the other pump.

6 INSTRUCTIONS FOR USE

SANITIZING SOLUTION

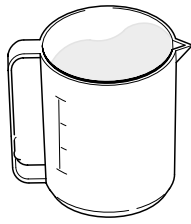

Step 1

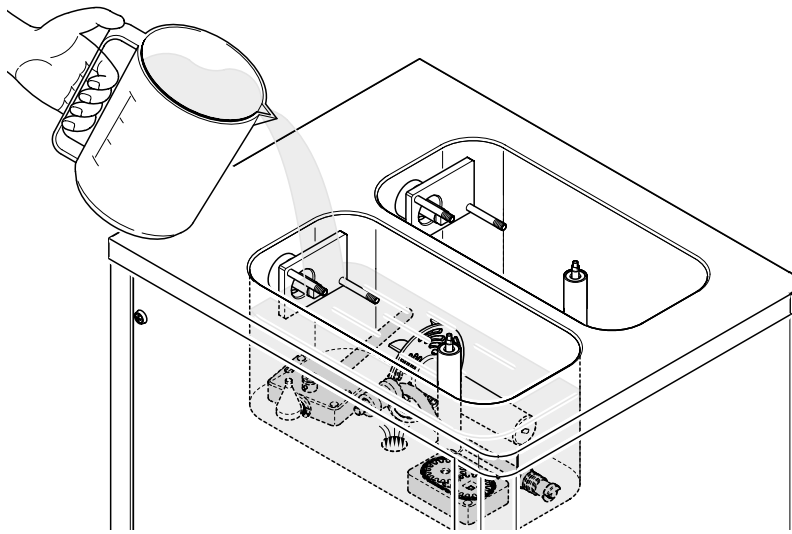

Step 2

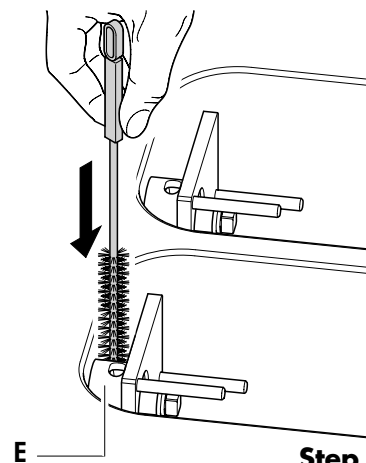
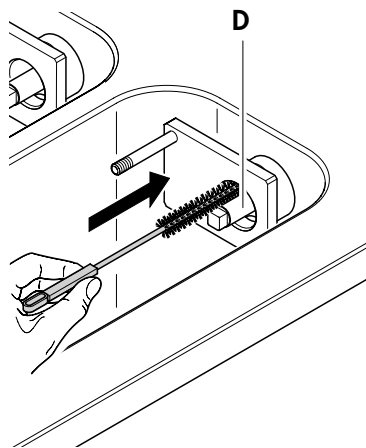
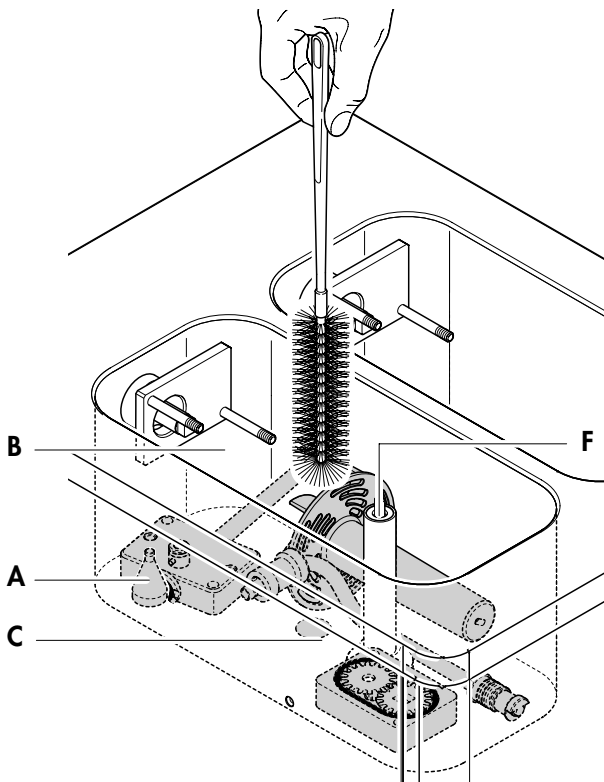

Step 3

SANITIZATION

To guarantee good routine maintenance and comply to current national or federal health regulations, you must clean all the organs coming into contact with the ice cream mix every day or according to the intervals set by the local regulations, and make sure that your staff always keep the machine really clean.



NOTE

Sanitization should be preceded by cleaning procedure (see paragraph "Cleaning" in this manual) and carried out just prior to startup.



NOTE

Make sure your hands are well cleaned or wearing sterilized gloves before carrying out the following operations.

Step 1

Prepare a sanitizing solution, diluting (see paragraph "Sanitizing solution").



NOTE

Follow the above mentioned instructions, because a too high concentration may damage the components, whereas a too little concentration would not ensure a correct cleaning.

Step 2

Spray the machine cover with some sanitizing solution, then pour the remaining sanitizing solution on the various parts previously placed on the storage hopper bottom and let the liquid flow inside the freezing cylinder and the extension hose.



NOTE

Once the parts and the hopper are sanitized, make sure your hands are clean before proceeding to the next step.

Step 3

While the solution passes into the cylinder, brush the level sensor "A" in the hopper, the exposed walls "B" of the hopper, the hole "C" for the mix entry, the pump components, the area around the shaft "D" and the pump connection "E", and the mixer "F".

6 INSTRUCTIONS FOR USE

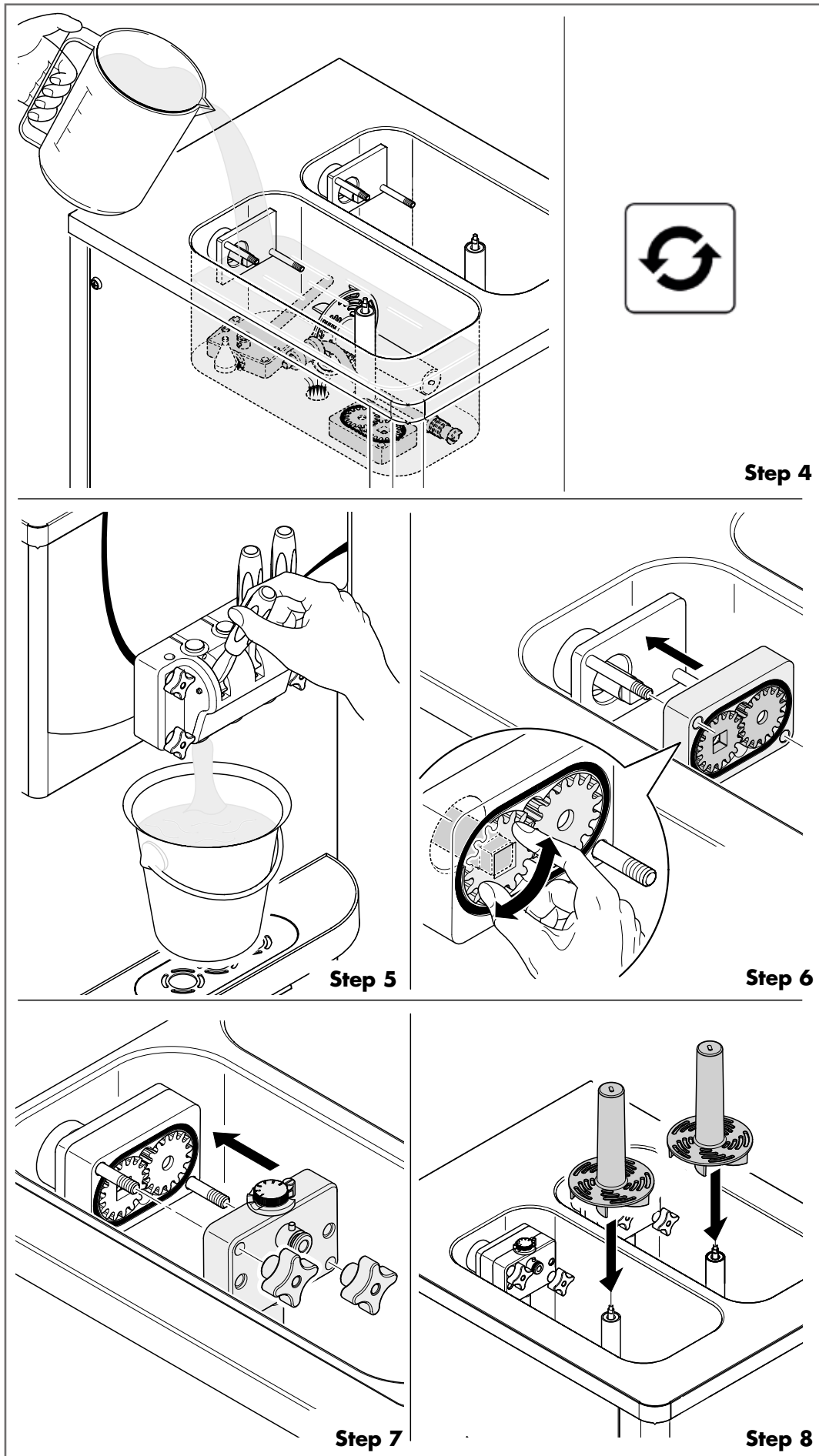

Step 4

Set the machine on WASH for 5 minutes. In this way, the sanitizing solution will be stirred within the cylinder.

Step 5

After about 5 minutes, place an empty bucket under the dispensing door and pull the lever to release all of the solution.



NOTE

To facilitate the release of the solution, make sure that the machine is placed on a perfectly horizontal surface.

Step 6

Mount the pump on its connection, taking care that the drive gear is well coupled with the squared shaft.

Step 7

Install the pump lid and lock by means of tightening knobs.

Step 8

Place the mixer on the specific drive shaft.



NOTE

Repeat steps 1-8 for the other hopper.



NOTE

STORAGE mode is not to be used in lieu of proper CLEANING and SANITIZING procedures, according to the intervals set by the current national or federal health regulations.

6 INSTRUCTIONS FOR USE

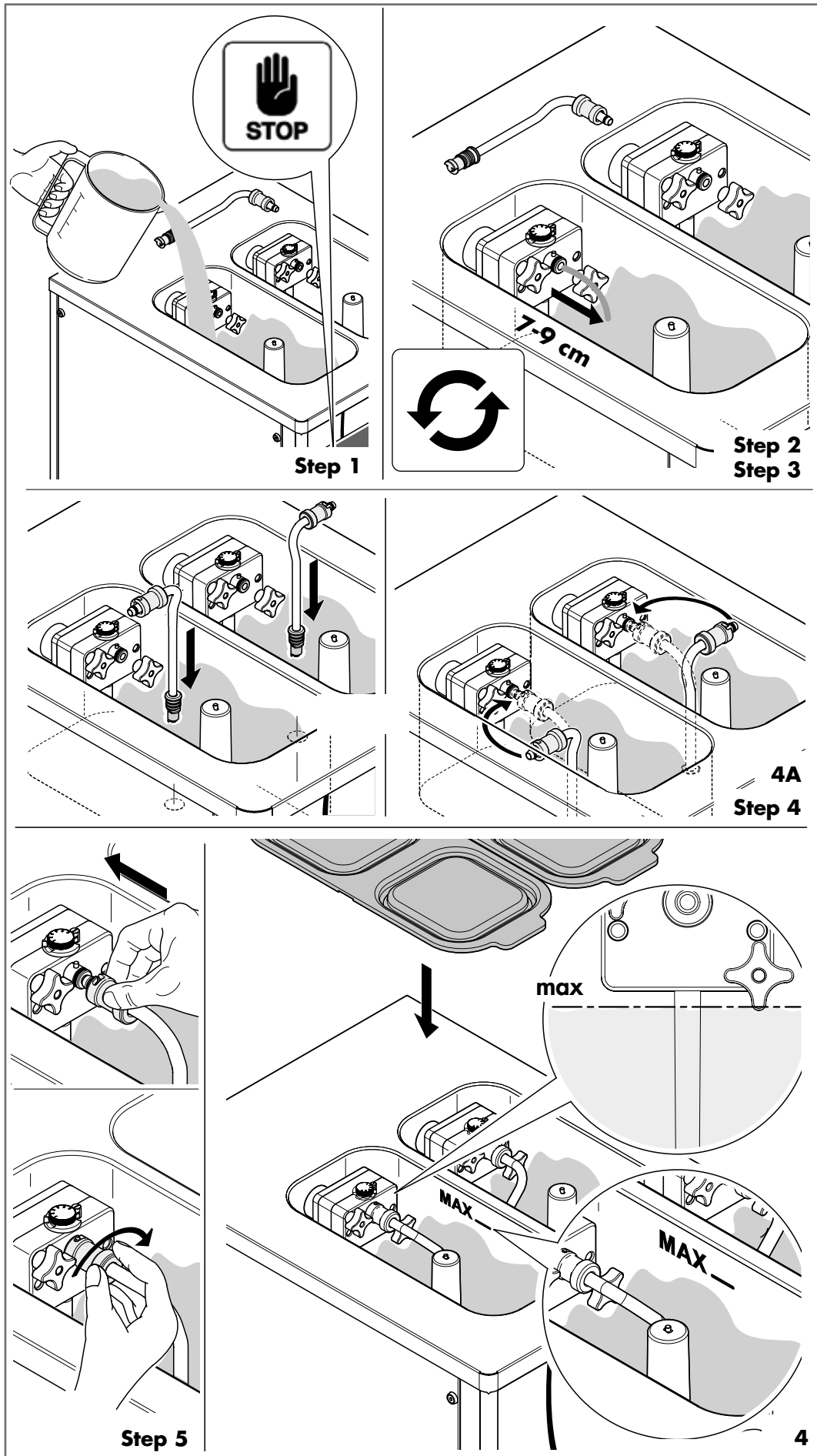

PRIMING THE MACHINE

NOTE
When priming the machine, use only freshly prepared mix. Make sure all tools used are sterilized.

NOTE
Make sure your hands are well cleaned or wearing sterilized gloves before carrying out the following operations.

Step 1
Make sure the machine is on STOP. Place the pre-mounted compression pipe above the machine and pour the mixture into the storage hopper. Wait for the mixture to go down into the cylinder.

NOTE
The level of the mix must never exceed the MAX sign on the hopper and, in any case, it must not reach the air intake holes, as indicated in the figure (4).

Step 2
In order to control the pump flow, activate it by the touch screen.

Step 3
Check that the right quantity of product comes out of the delivery hole in the cover. The mix should flow smoothly and continuously, producing a 7-9 cm jet.

Step 4
Insert the compression pipe into the hole inside the hopper, as indicated in the figure, and turn it 90° counterclockwise towards the pump. Respect the position and the rotation direction of the compression pipe, as indicated in the figure (4A).

Step 5
Insert the bayonet joint and rotate it to secure the compression pipe to the pump body.

Mix choice
The quality of the ice-cream depends greatly on the quality of the mix used.

See the product supplier's instructions and follow the advice below to prepare and preserve the mix:

- 1) use only specially prepared mix for use in machines express freezing machines or, alternatively, make your own mix with quality natural ingredients.
- 2) the mix temperature should not exceed 10°C (50°F).

In the pump fed units, we suggest using a fluid, not too thick mix, without lumps or fruit pieces bigger than 0,5 mm², that might



5

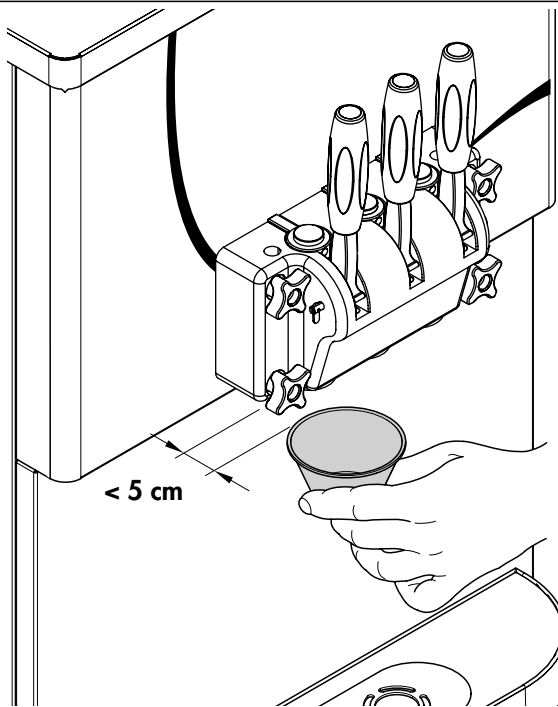

Step 1

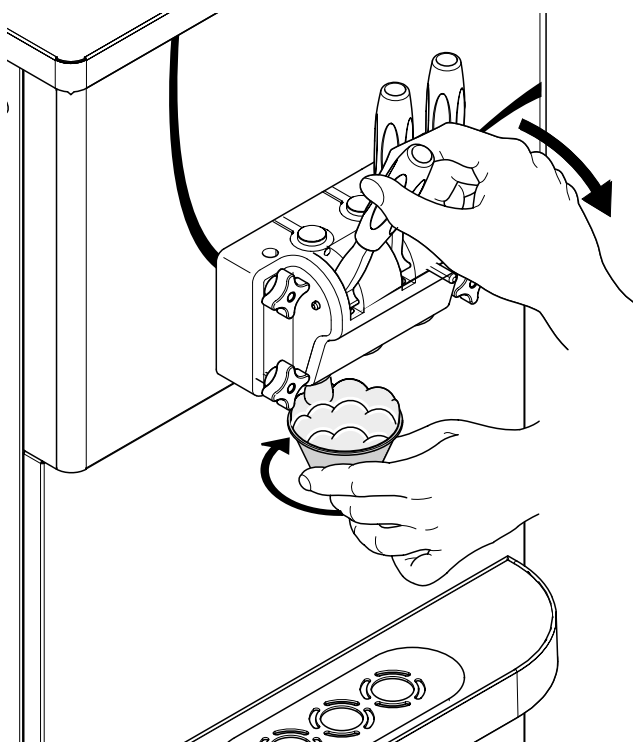

Step 2

cause the malfunction of the machine and break the beater, due to failed loading of the freezing cylinder.



NOTE

Repeat steps 1-3 for the other hopper.

PRODUCTION

Set the machine to PRODUCTION mode (5).

In the above mode of operation, the machine produces the ice cream and keeps in automatic a constant spare quantity inside the cylinder.

The liquid mix is kept at a refrigerated temperature in the storage hopper.

When the motor and the compressor stop, the machine is ready for the delivery of ice cream.

DELIVERY OF THE ICE CREAM

Step 1

Place the cup or the cone under the dispensing door, ensuring that the distance from the photocell does not exceed 5 cm.

To deliver the product, just lower one of the dispensing levers: the left-hand side lever for the flavour inside the left-hand hopper; the right-hand lever for the right-hand hopper and the central lever for the mixed flavour.

As soon as the product begins to exit, it is advisable to move the cup or the cone in a circular direction, so as to give the ice cream the characteristic conical shape.

After dispensing of the desired quantity, close the lever and move the cup or the cone quickly down to finish the tip of the shape.

Step 2

Try to be regular in the distribution of the product: about every 15 seconds (BC 250 PM - BV 250 PM - BV 261 PM) - about every 12 seconds (MV 254 PM) - about every 10 seconds (HV 254 PM), for servings of 75g. / 2,65 oz.

If you exceed the specified capacity, the machine may deliver too soft ice cream, that is not of the right consistency, or it may stop.

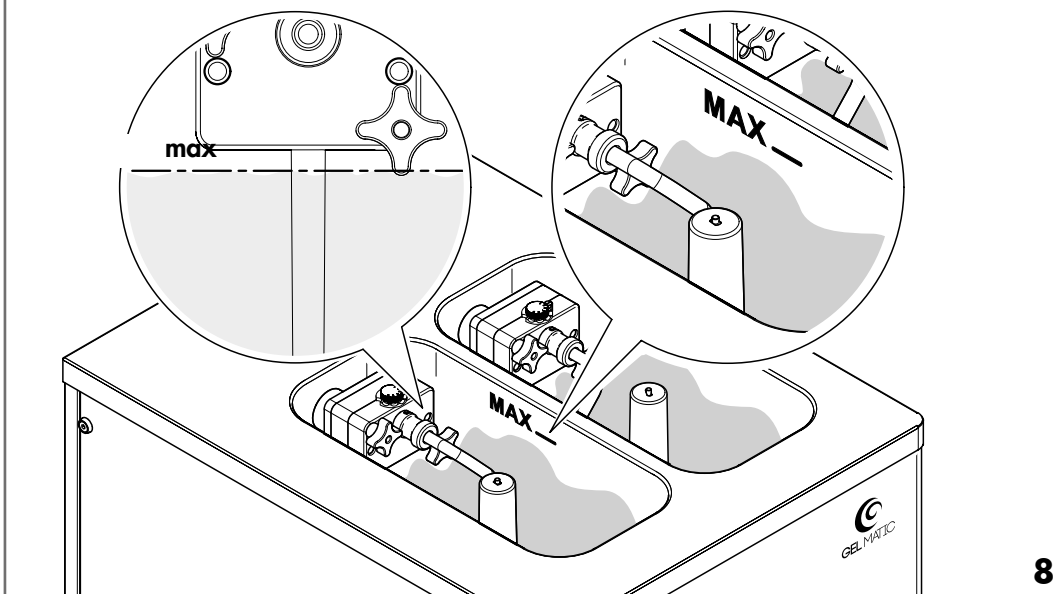
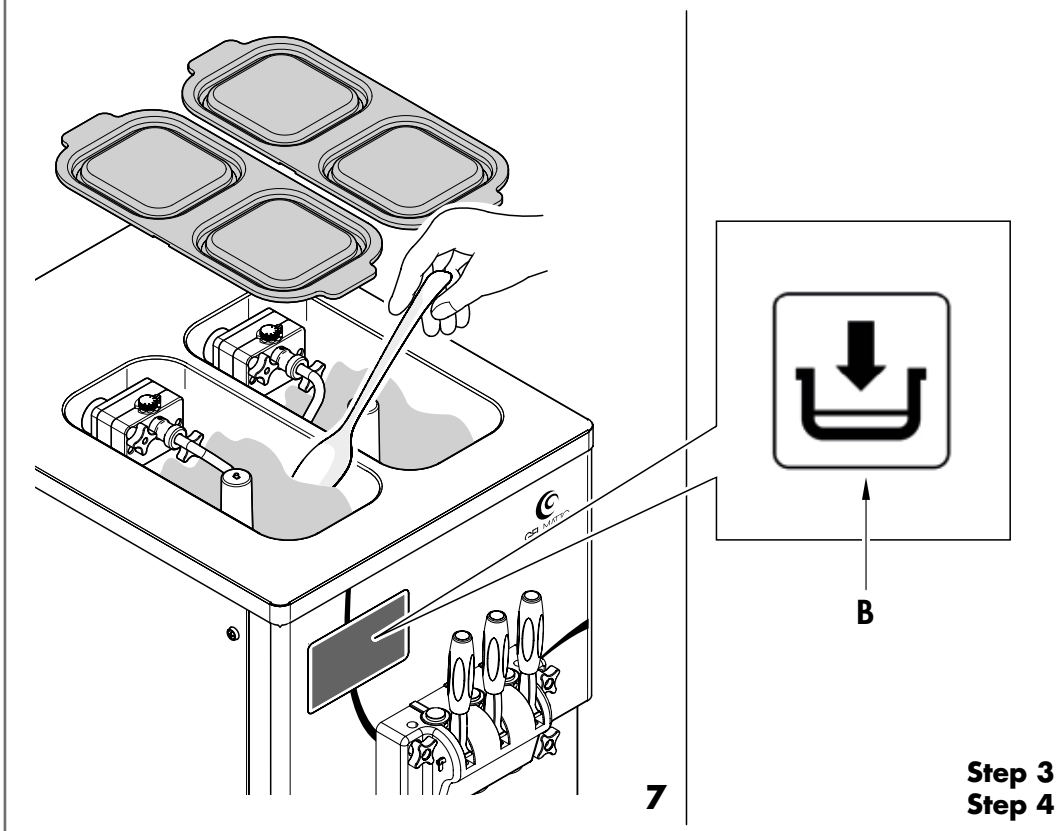
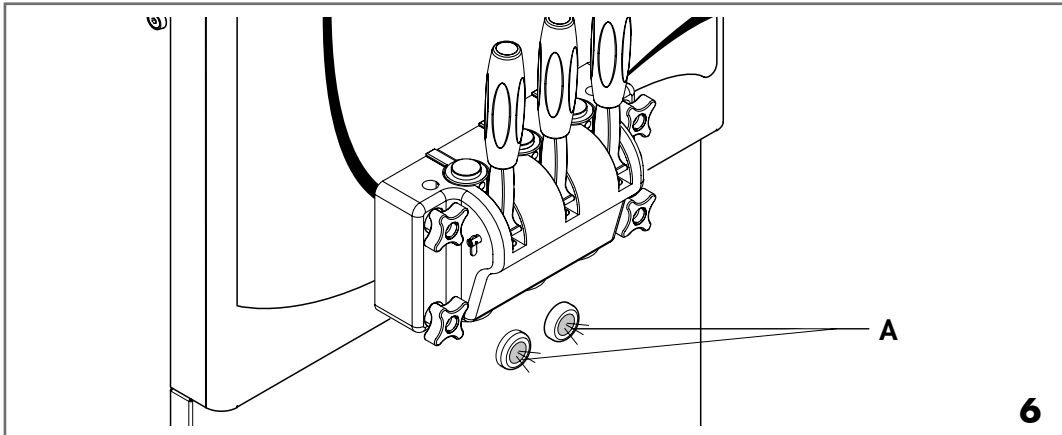

WARNING
Make sure the photocell "A" (6) is clean. Do not place any reflective objects in front of the photocell, such as mirrors, glasses or other photocells.

WARNING
NEVER operate the machine if there is water in the storage hopper, with the exception of the washing operations. In fact, water freezing inside cylinder might break the beater and damage the transmission unit.

NOTE
For machines WITHOUT mixer, stir the mixture periodically during the day, using a rubber spatula (7), so as to maintain a uniform temperature inside the hopper and to avoid any deposit of ice and the separation of ingredients, especially after long periods without dispensing. It is recommended to repeat the operation every 30 minutes.

Step 3
If the consistency of ice cream does not meet your needs, see paragraph "Adjusting the consistency of the ice cream". It is recommended to evaluate the consistency after delivering at least 10 portions.

Step 4
When in use, a yellow warning icon (B) on the touch screen display will indicate that the product in the hopper is below the minimum level. At the end of the countdown, during which you must add the product into the hopper, the icon (B) will turn red and will prevent the machine operation in order to avoid damaging the components. If the user changes mode and suddenly selects PRODUCTION mode again, the icon will turn red immediately.

NOTE
The level of the mix must never exceed the MAX sign on the hopper and, in any case, it must not reach the air intake hole, as indicated in the figure (8).

WARNING
To avoid damage to the beater inside the freezing cylinder, NEVER use the machine with the hopper completely empty.



9

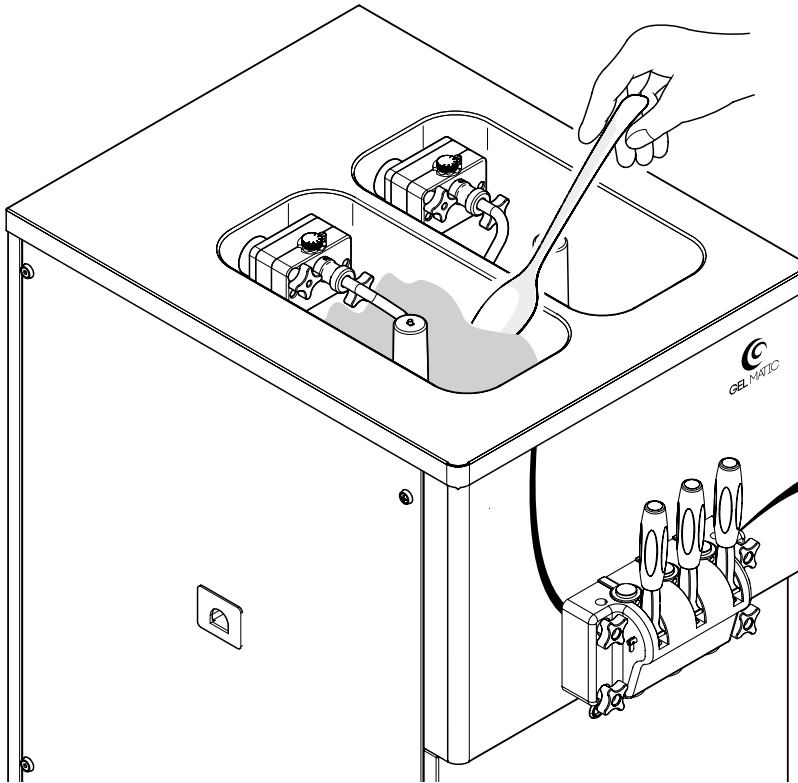

10

LONG TIME WITHOUT DISPENSING

Storage Function

The STORAGE mode makes the machine cool all the mix contained in the unit at an adjustable temperature from 2°C to 4°C (from 36°F to 39°F), saving a considerable amount of energy during slack periods (during closing times or at night). The mix storage temperature is displayed on the touch screen monitor placed on the front panel. To display the storage temperature, see paragraph: "Storage hopper temperature display".

The storage function can NOT be used to replace the procedures of cleaning and sanitizing.

To operate the machine in this mode, select STORAGE on the touch screen monitor (9).

Resetting normal production

1) After a long period when the machine has been in STORAGE mode, you will need to mix the product properly inside the hopper before going to PRODUCTION mode (10).



NOTE

In case of daily opening after overnight storage, see paragraph "Daily opening procedures".

2) Set the machine to PRODUCTION mode (11).

3) Take out about 0.5 l of mixture from the cylinder BC 250 PM - BV 250 PM 0.75 l

l of mixture pouring it back into the hopper (12).

4) Wait for a couple of minutes that the machine is ready for standard ice cream production.



11

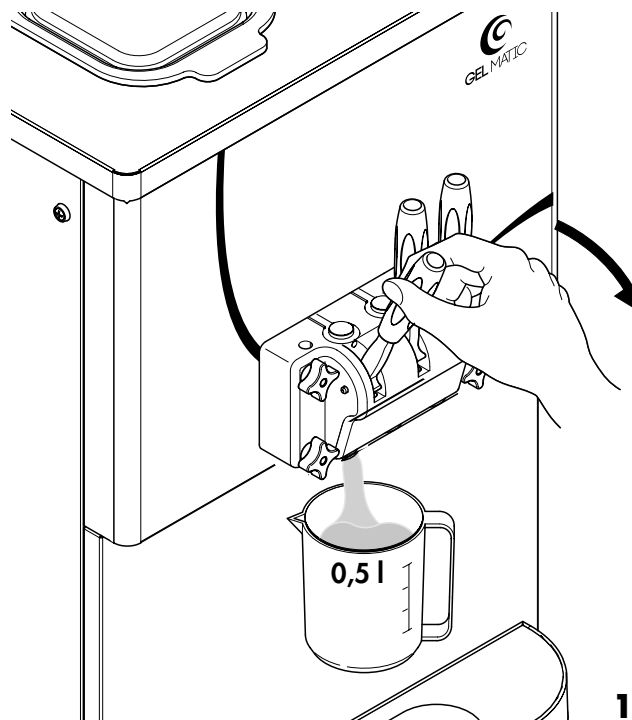

12

6 INSTRUCTIONS FOR USE

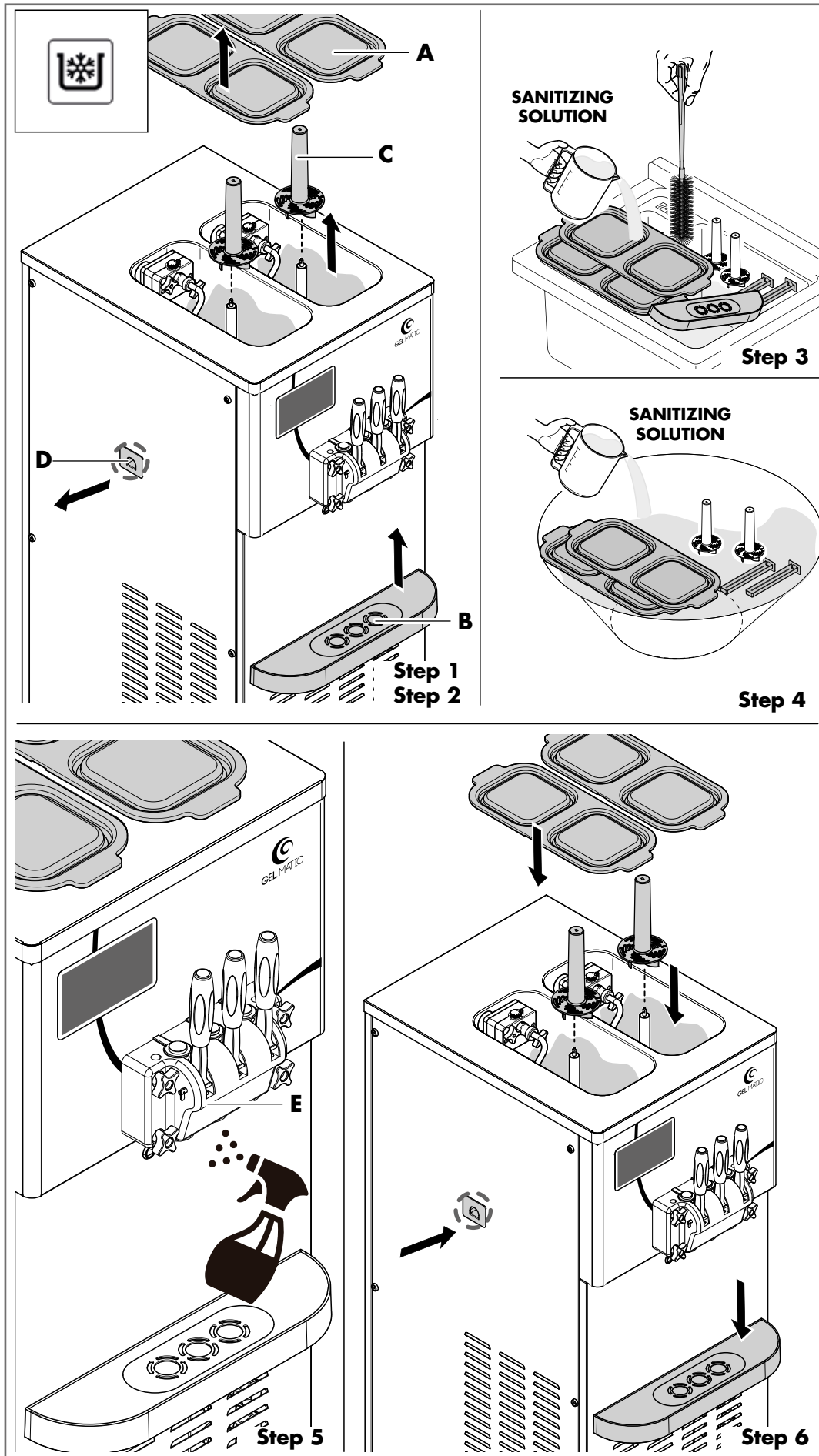

DAILY CLOSING PROCEDURES



NOTE

Make sure your hands are well cleaned or wearing sterilized gloves before carrying out the following operations.

Step 1

Set the machine to STORAGE mode.

Step 2

Remove the hopper lids (A), the drip-tray (B), the mixers (C) and the condensate drip-trays (D).

Step 3

Pour the sanitizing solution into the sink and brush the components disassembled thoroughly. Rinse using clean water.

Step 4

Soak all the removed parts in the sanitizing solution and leave for at least 5 minutes. Place all pieces on a clean, dry, sanitized surface and let them dry.

Step 5

Spray the sanitizing solution on the dispensing door (E), brush it and dry by a cloth.

Step 6

Reposition the mixers in the storage hoppers. Reposition the condensate drip-trays and the hopper lids.

DAILY OPENING PROCEDURES



NOTE

Make sure your hands are well cleaned or wearing sterilized gloves before carrying out the following operations.

Step 1

Spray the sanitizing solution on the dispensing door (E), brush it and dry by a cloth.

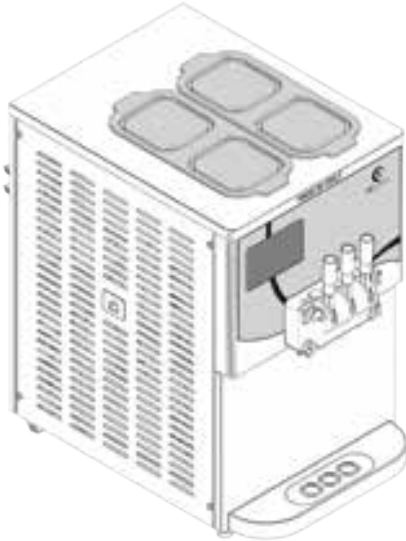
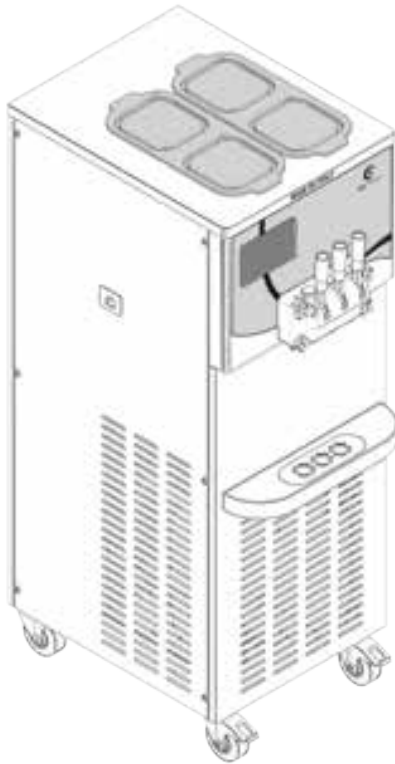
**BC 250 PM****BV 250 PM**

CLEANING

The machine must be thoroughly washed and restarted at regular intervals.



NOTE

Make sure your hands are well cleaned or wearing sterilized gloves before carrying out the following operations.



NOTE

The following operations must be carried out in addition to the regular daily cleaning procedures.



NOTE

For the wash procedure, respect current local health regulations.

The intervals between each wash cycle depends on various factors:

- the local health and safety regulations establishing the accepted bacterial charge (pH)
- the amount of ice cream being delivered (permanence of the liquid mix inside the storage hopper)
- the bacterial levels of the mix used (mixes prepared with powdered milk or water last longer than those prepared using fresh milk and/or cream).



NOTE

For machines that work with products made from yogurt, it is recommended to clean the pump unit every day. Furthermore, it is recommended to wash every 30 days the pump unit with special limestone detergent, to remove the deposit / calcification of the yogurt.

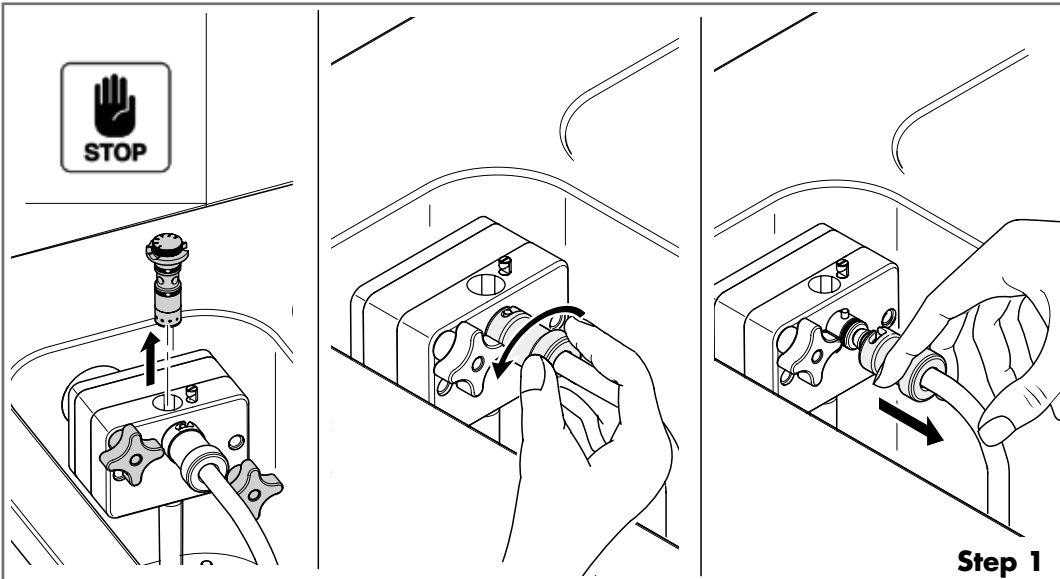

Step 1



NOTE
The reuse of the mix adversely affects the washing and sanitization effect. The mix cannot be reused.

If required by local regulations, follow these steps every day. To make it easier to clean the machine, we recommend melting the ice cream left inside the machine as follows:

Step 1
Set the machine to STOP. Press and rotate the overrun regulator to remove it.



NOTE
If the machine has still the product inside, it is necessary to release the pressure inside the cylinder (see paragraph "Disassembly of the pump").

Turn the bayonet joint and release it from the pump body, as indicated in the figure.

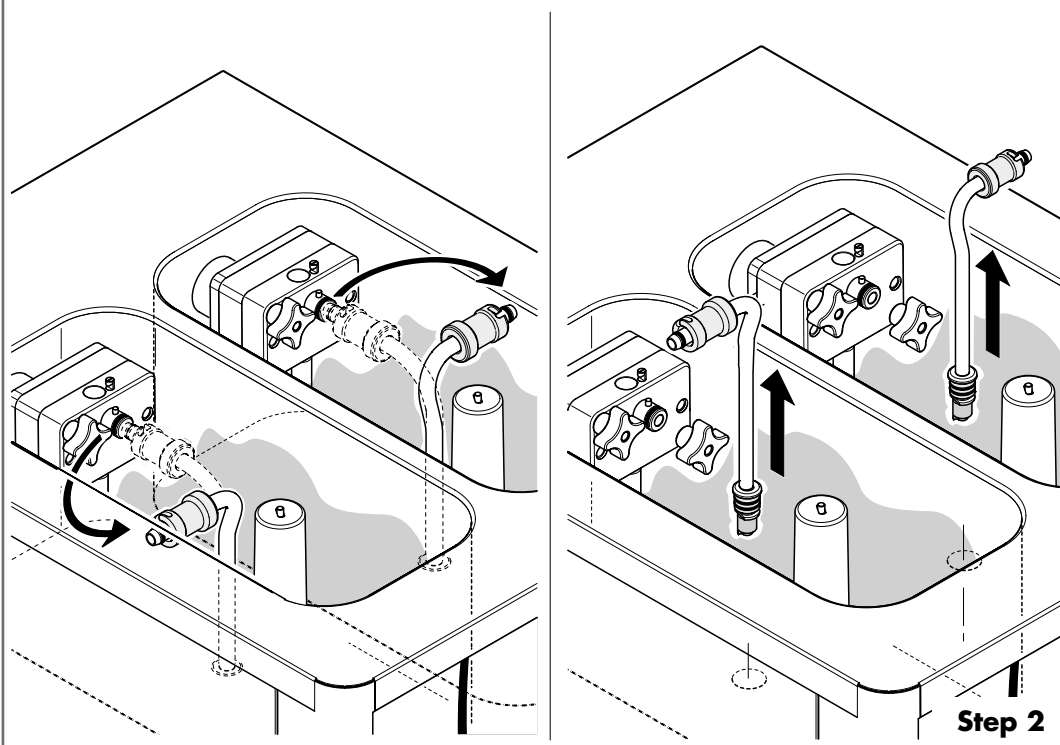

Step 2

Step 2
Rotate the compression pipe by 90° and remove it from the hopper. Respect the position and the rotation direction of the compression pipe, as indicated in the figure.

Step 3
Remove the bayonet joint and remove the non-return valve and the gaskets from the compression pipe.

Step 4
Completely unscrew the fastening knobs and remove the pump from the hopper. In this sequence, first remove the pump cover and then the pump body with its gears.

Step 5
Remove the gears from the pump body.

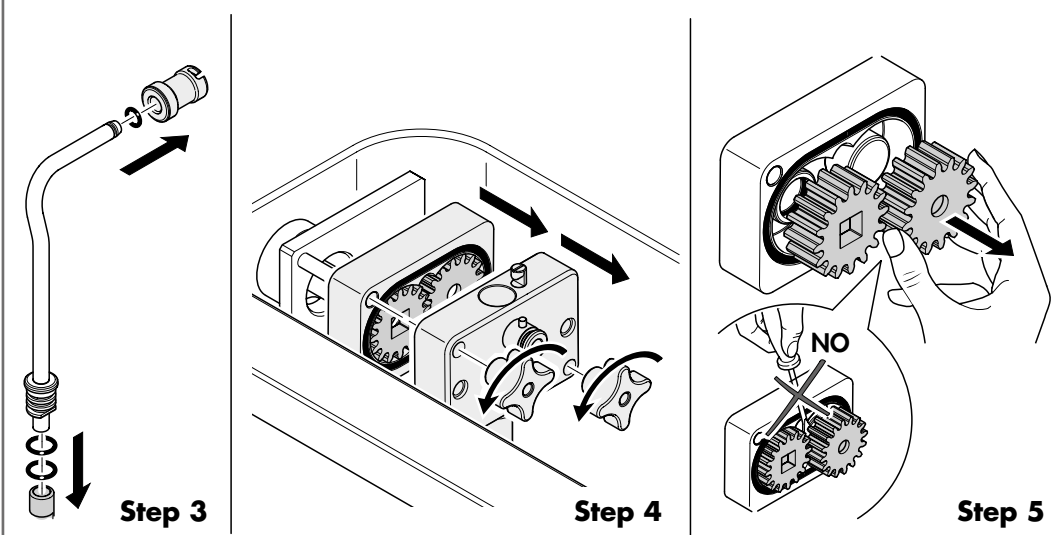

Step 3

Step 4

Step 5



WARNING
Do not use tools to extract the gears; use your hands and pay attention to any impact or fall that can damage them.

6 INSTRUCTIONS FOR USE

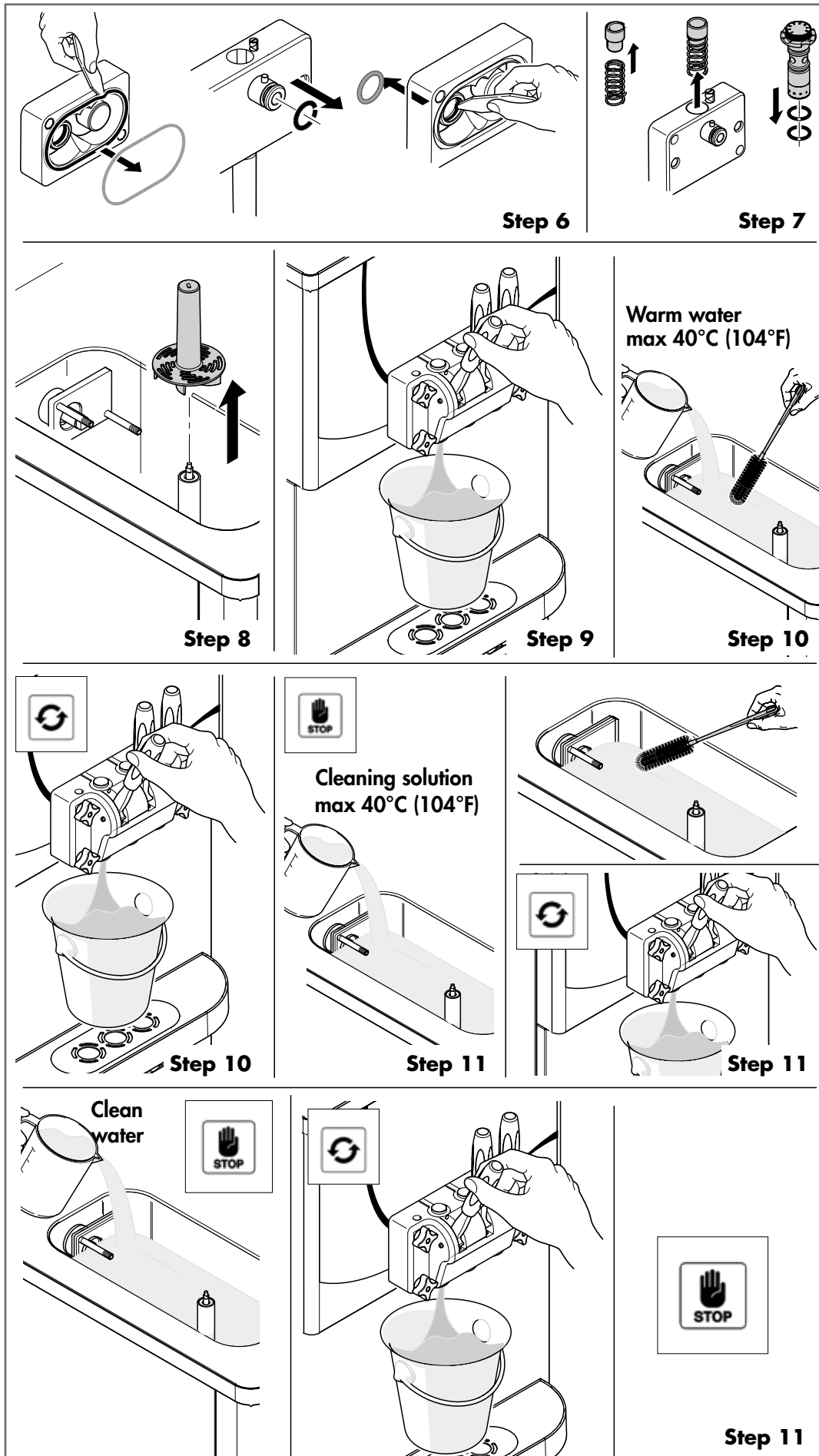

Step 6
Remove the gaskets on the pump. Use the special tool, do not use screwdrivers and tools in order to avoid cutting the gaskets.

Step 7
Remove the by-pass valve with its spring and O-ring gask

Step 8
Remove the mixer, pulling it from its transmission shaft.

Step 9
Pull the lever to pour out all the mix contained in the machine (hopper and cylinder).

Step 10
Pour about 6 liters (BC 250 PM - BV 250 PM) of water into the hopper, if possible use warm water (max 40°C/104°F) and wait for 5 minutes. Use a brush to remove the ice cream leftovers from the hopper walls. Drain all the water using the lever. If necessary, pour more water (about 6 liters BC 250 PM, BV 250 PM) to remove any remaining product and drain again, by selecting WASH function and pulling the dispensing lever. Once released the product, set the machine to STOP.

Step 11
Prepare a cleaning solution (see paragraph "Cleaning solution"). Pour about 6 liters (BC 250 PM - BV 250 PM) of cleaning solution into the storage hopper, thoroughly clean it, and drain by selecting WASH function and pulling the lever. Once released the product, set the machine to STOP. Pour another 6 liters BC 250 PM, BV 250 PM of clean water to rinse. Select WASH function and pull the dispensing lever to drain. Once released the product, set the machine to STOP.

6 INSTRUCTIONS FOR USE

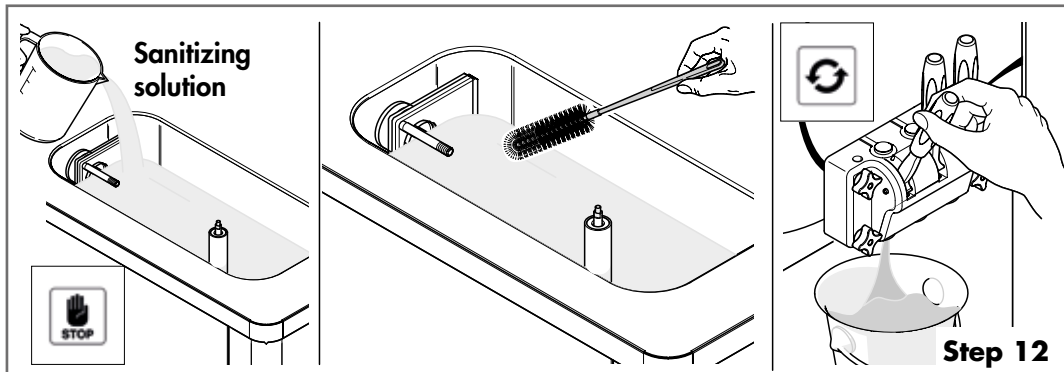

Step 12

Prepare a sanitizing solution (see paragraph "Sanitizing solution"). Pour about 6 liters BC 250 PM - BV 250 PM of sanitizing solution into the storage hopper, brush thoroughly and leave for 5 minutes. Select WASH function and pull the dispensing lever to drain. Once released the product, set the machine to STOP.



NOTE

Repeat steps 1&12 for the other hopper.

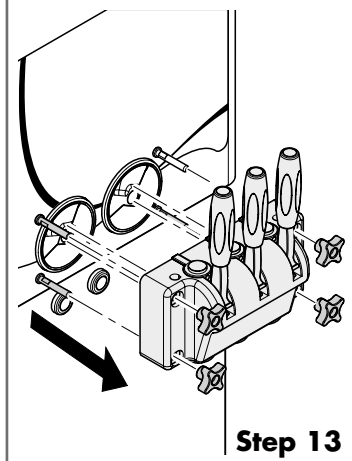

Step 13

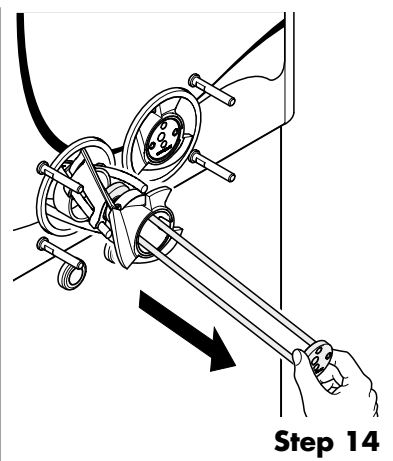

Step 14

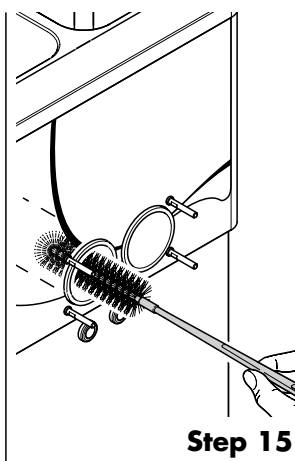

Step 15

Step 13

Remove the dispensing door (see paragraph "Disassembly of the dispensing door") and the cleaning solution. Rinse with clean water.

Step 14

Remove the stirrer (see paragraph "Disassembly of the beater"), add the cleaning solution and thoroughly clean the cylinder. Rinse using clean water.



NOTE

Repeat step 14 for the other beater.

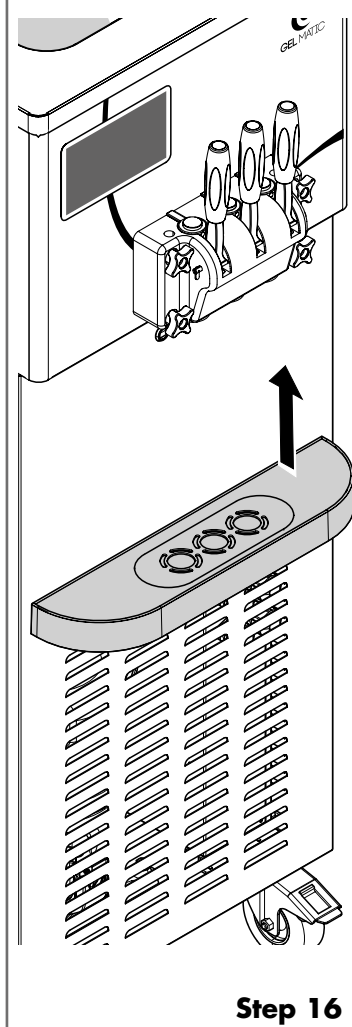

Step 16

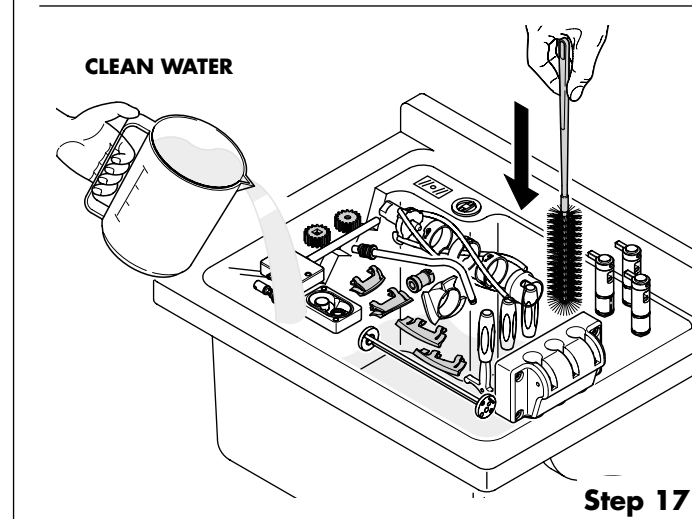
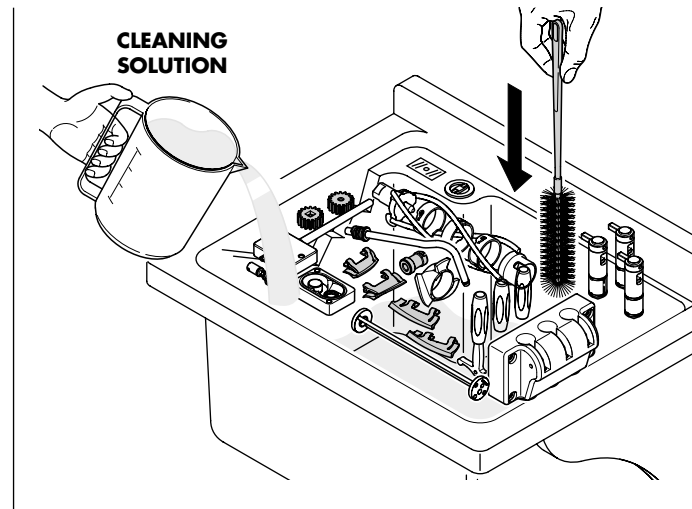

Step 17

Step 15

Soak the brush in the sanitizing solution and brush the cylinder thoroughly. Dry with a sterilised cloth.

Step 16

Remove the drip-tray and clean thoroughly (see paragraph "Disassembly of the drip-tray").

Step 17

Wash all parts in the dishwasher or in the sink, using the brushes that come with the machine and the detergent. Make sure to remove any remaining mix and lubricant. Rinse using clean water:

- pump (fully disassembled)
- dispensing door (lever, pistons and relevant gaskets)
- beater (remove the gasket from the bottom of the beater, scraper blades, worm and counter rotating shaft)
- mixer
- drip-tray.



WARNING

Wash the O-rings separately, making sure they don't fall into the sink or the dish washing machine drainage.

6 INSTRUCTIONS FOR USE

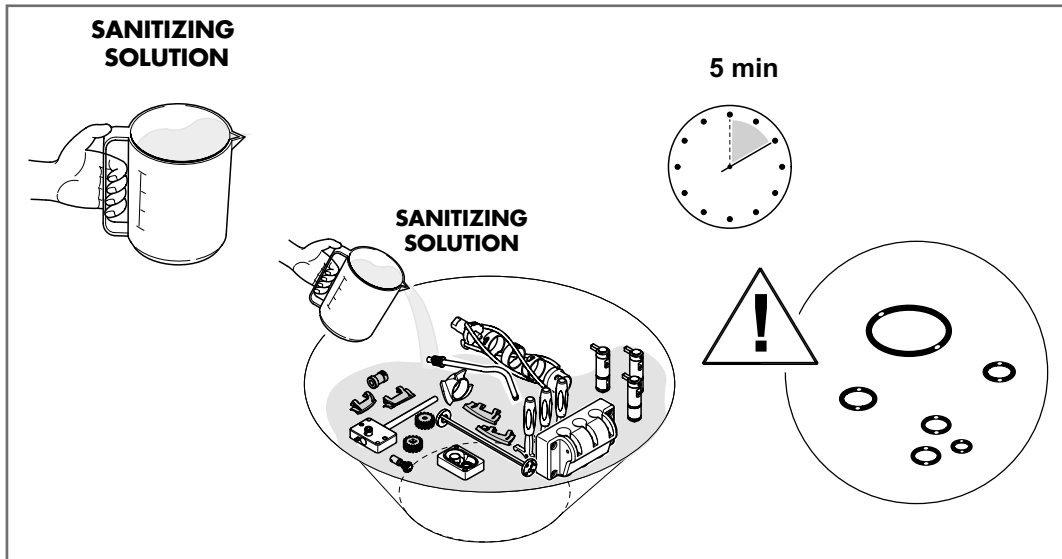

Step 18

Prepare a sanitizing solution (see paragraph "Sanitizing solution").



NOTE

Follow the instructions on the sanitizing product label, as too strong a solution could damage the components, while a very concentrated solution does not ensure adequate cleaning.

Soak all the removed parts in the sanitizing solution and leave for at least 5 minutes.

Place all pieces on a clean, dry, sanitized surface and let them dry.

Use a soft cloth or sponge to clean the outside side panels. Never use pressurized water, as this may damage the machine (A).

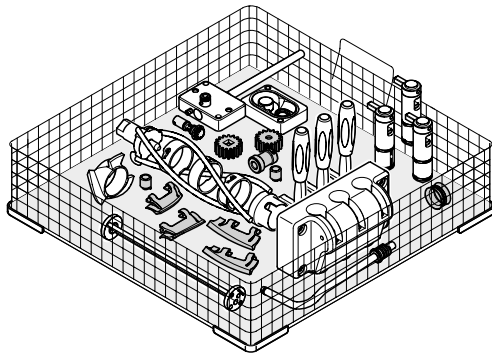

Step 18

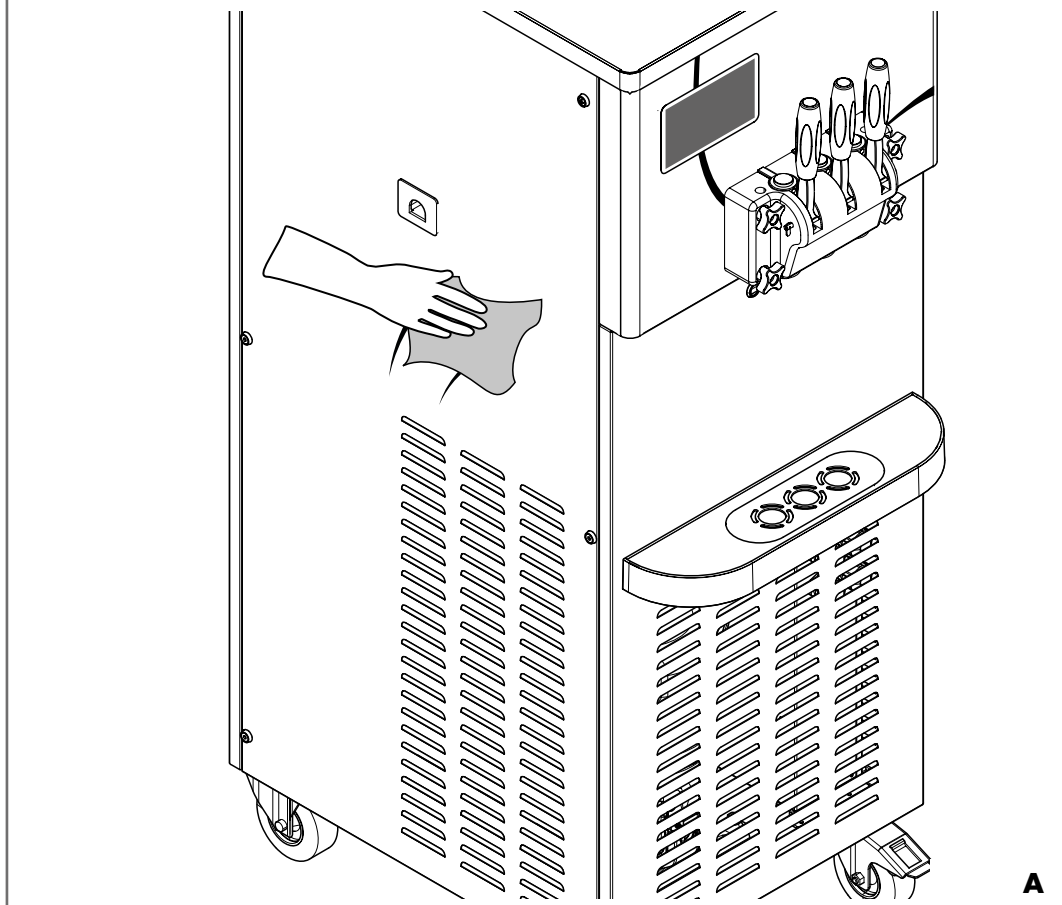

WARNING

After washing operations, make sure that there is no residual water inside the machine. In fact, water freezing inside the cylinder during machine operation might damage the beater and the transmission unit.



WARNING

During some cleaning operations on the machine, it is possible to control the movement of the beater even when the dispensing door has been removed. To eliminate hazards, clean the machine when power supply is off.



WARNING

The moving beater is hazardous during cleaning (mechanical hazard).

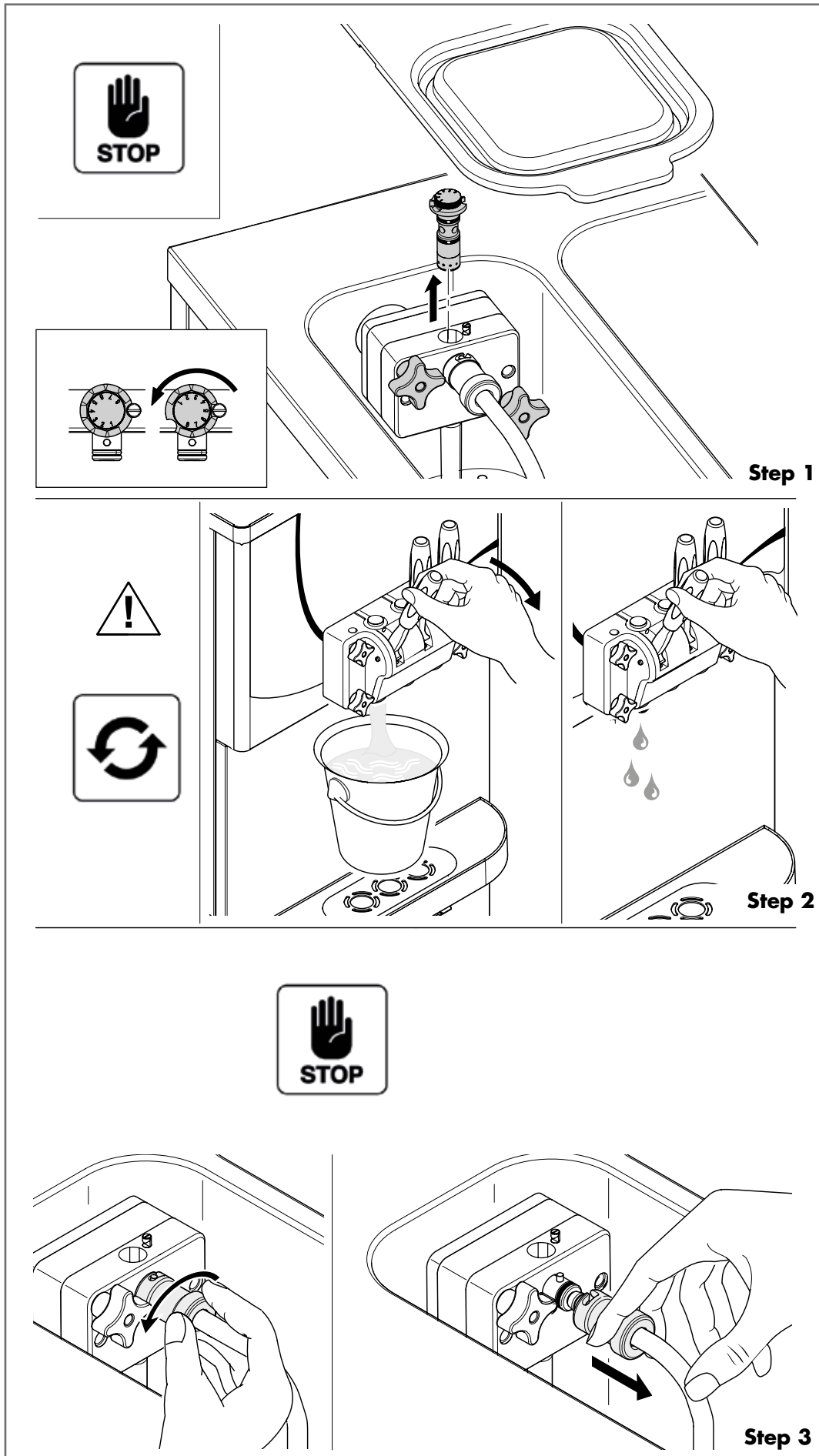

DISASSEMBLY OF THE VARIOUS COMPONENTS

Disassembly of the pump

Step 1

If the machine has still the product inside, it is necessary to release the pressure inside the cylinder. Make sure that the machine is in STOP mode, and remove the over-run regulator.

Step 2

Set the machine to WASH mode and, using the lever, release a bit of product (about 1 liter) up to totally eliminate the pressure present in the machine (hopper and cylinder).

Step 3

Set the machine to STOP. Turn the bayonet joint and release it from the pump body, as indicated in the figure.

6 INSTRUCTIONS FOR USE

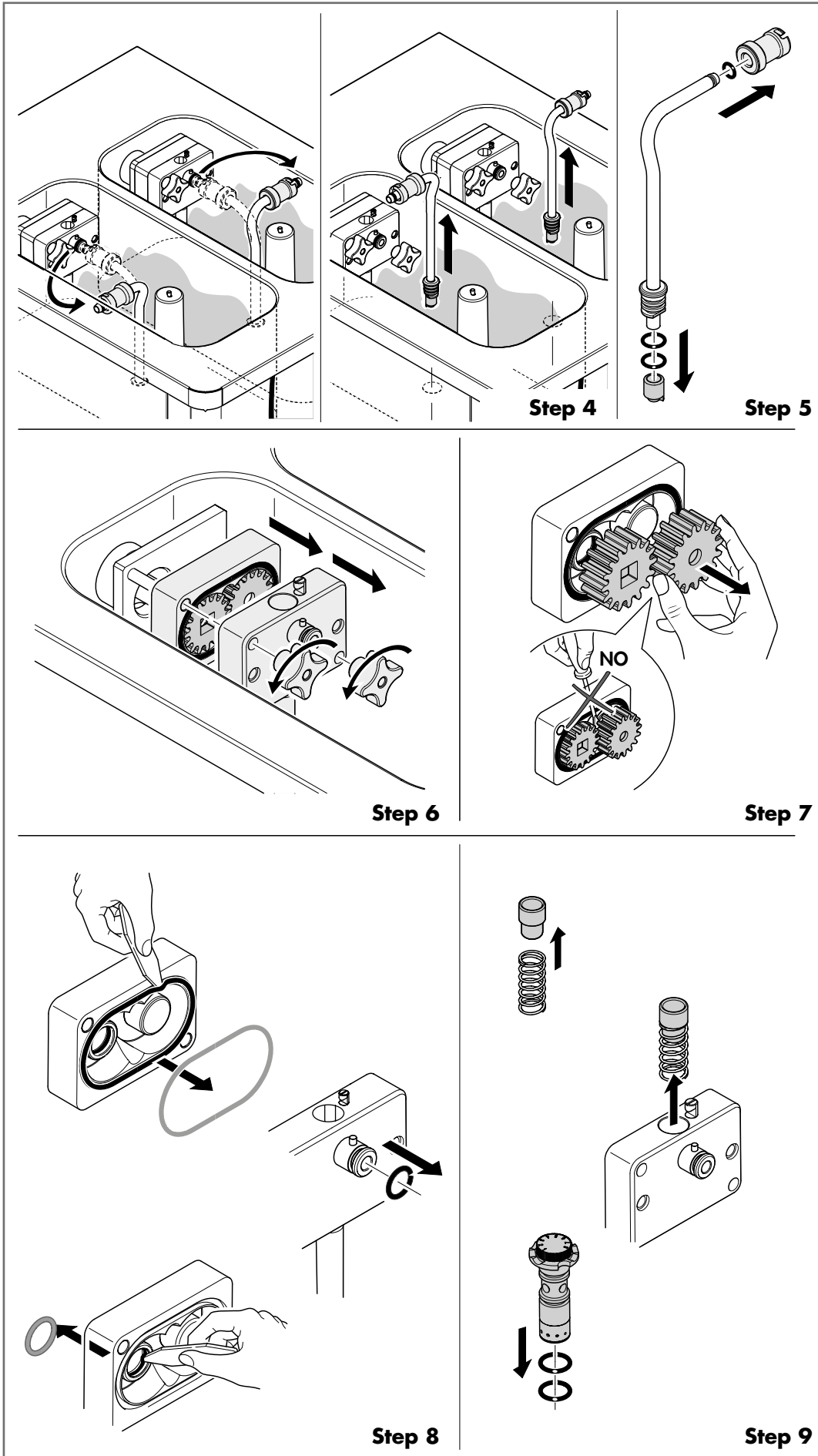

Step 4
Rotate the compression pipe by 90° and remove it from the hopper. Respect the position and the rotation direction of the compression pipe, as indicated in the figure.

Step 5
Remove the bayonet joint and remove the non-return valve and the gaskets from the compression pipe.

Step 6
Completely unscrew the fastening knobs and remove the pump from the hopper. In this sequence, first remove the pump cover and then the pump body with its gears.

Step 7
Remove the gears from the pump body.

WARNING
Do not use tools to extract the gears; use your hands and pay attention to any impact or fall that can damage them.

Step 8
Remove the gaskets on the pump. Use the special tool, do not use screwdrivers and tools in order to avoid cutting the gaskets.

Step 9
Remove the by-pass valve with its spring and O-ring gaskets from the overrun regulator.

NOTE
Repeat steps 1-9 for the other pump.

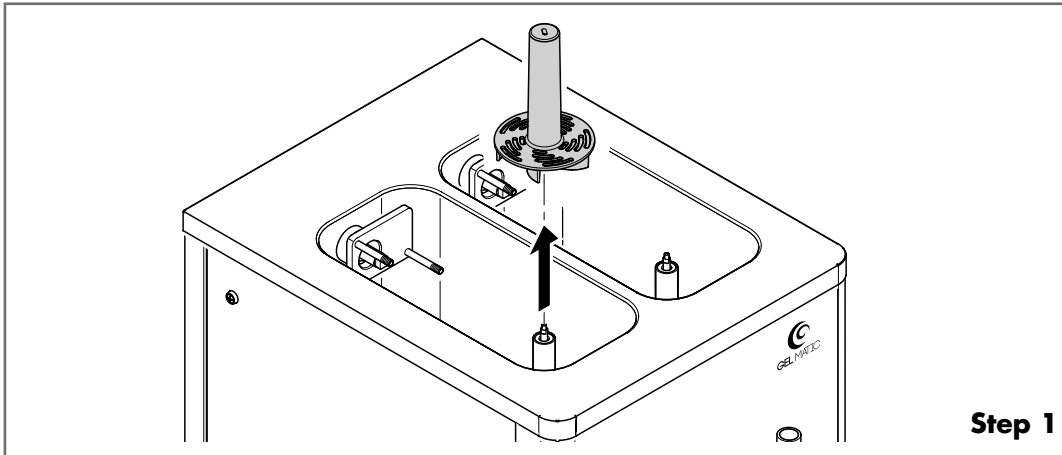

Step 1

Disassembly of the mixer

Step 1

For machines with mixer: remove the mixers, pulling them from the shafts.

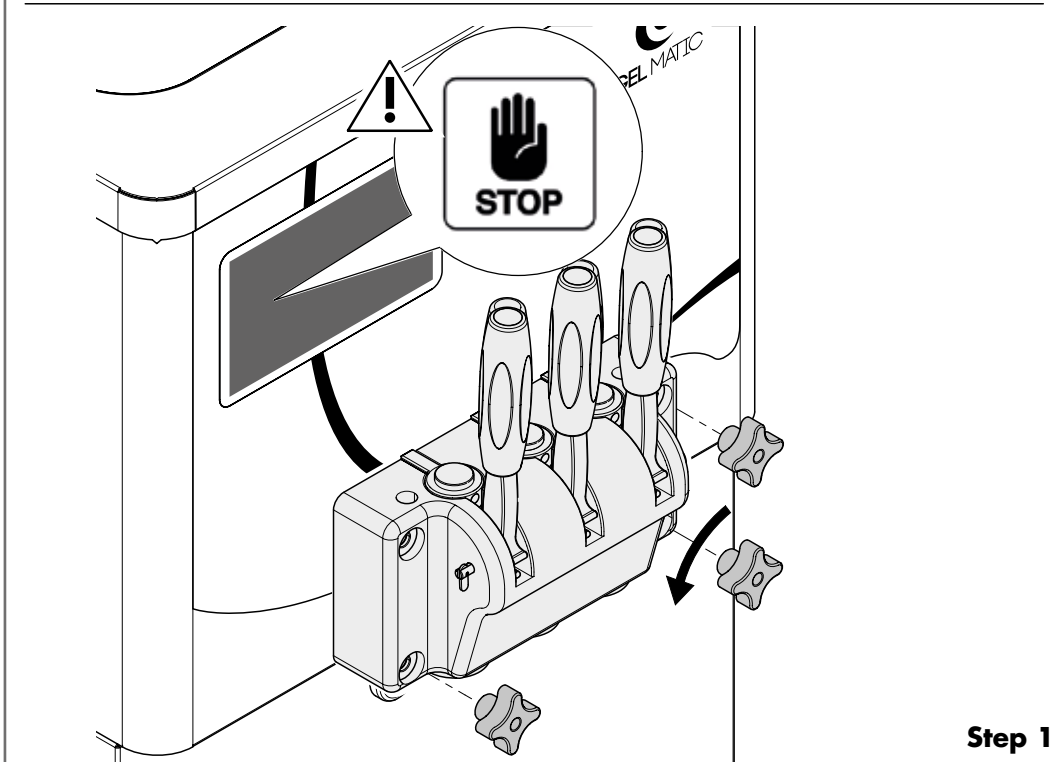

Step 1

Disassembly of the dispensing door

Before removing the dispensing door, make sure that the hopper and the cylinder are empty and that the power supply is disconnected.

Step 1

Unscrew the knobs tightening the dispensing door.

Step 2

Remove the dispensing door.

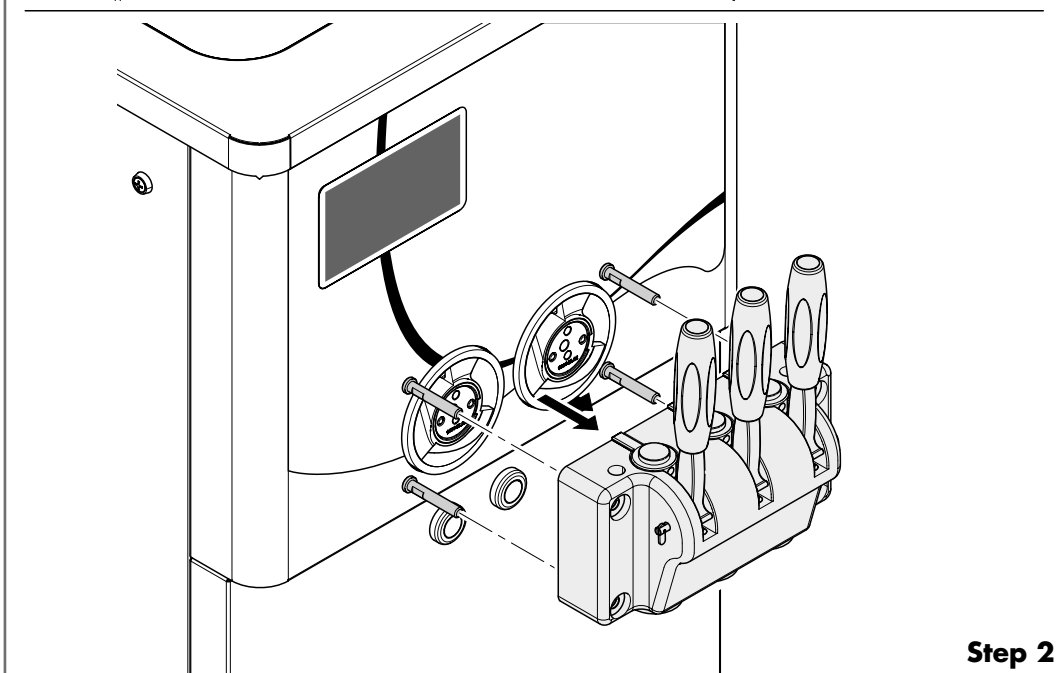

Step 2

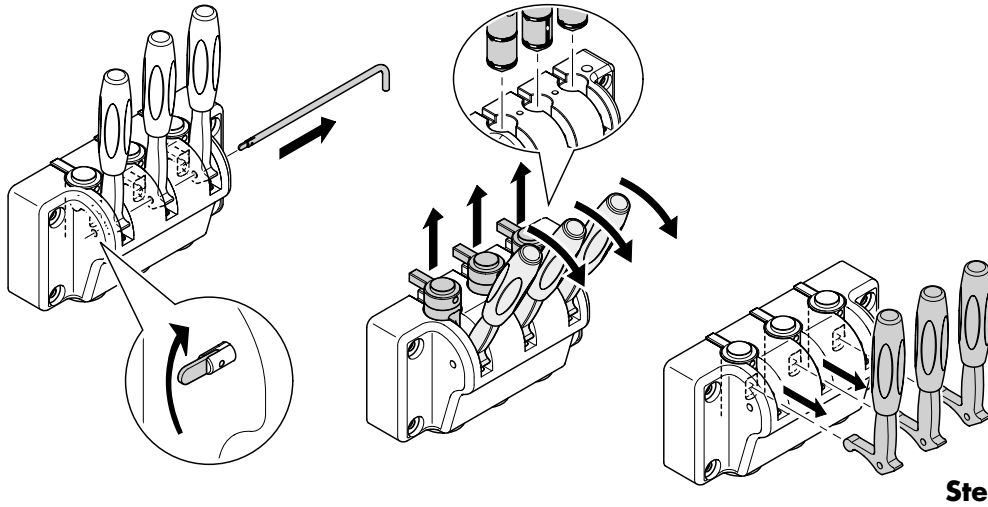

Step 3

Step 3

Slide out the lever fastening pin and then extract the pistons, by using the levers.

Step 4

Remove the gaskets on the back of the dispensing door and O-rings of the pistons with the help of the tool for O-ring removal supplied.



WARNING

Make sure that, during the disassembly of the dispensing door, the machine is always in STOP mode.

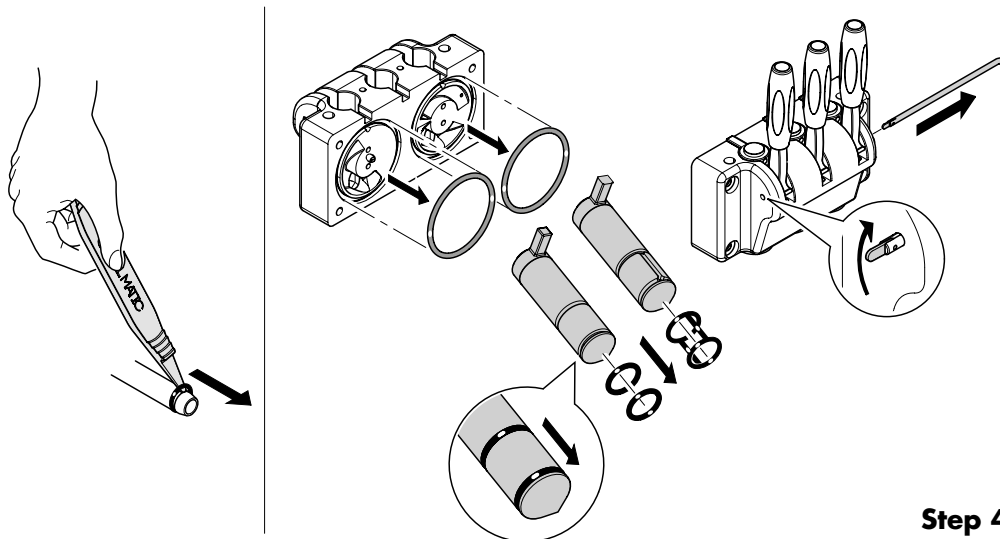

Step 4

Disassembly of the SP2 beater

Step 1

Remove the beater from the cylinder.

Step 2

Remove the sealing gasket.



NOTE

Repeat steps 1&2 for the other beater.

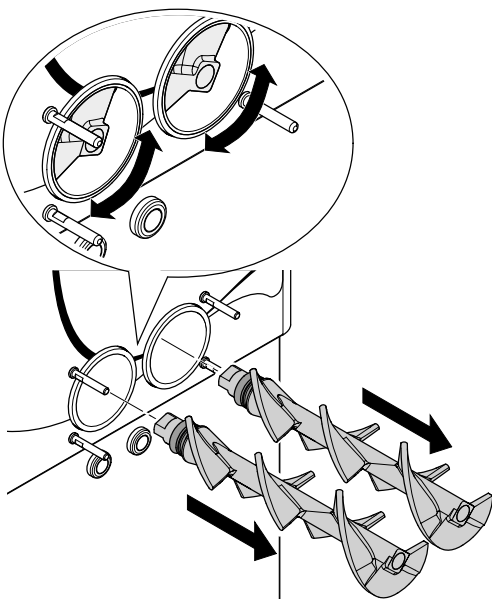

Step 1

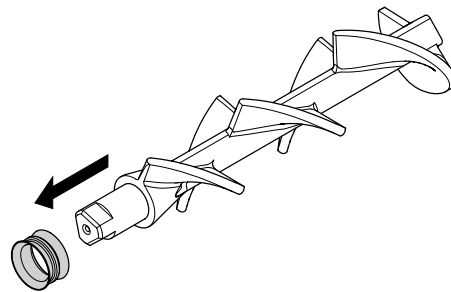

Step 2

6 INSTRUCTIONS FOR USE

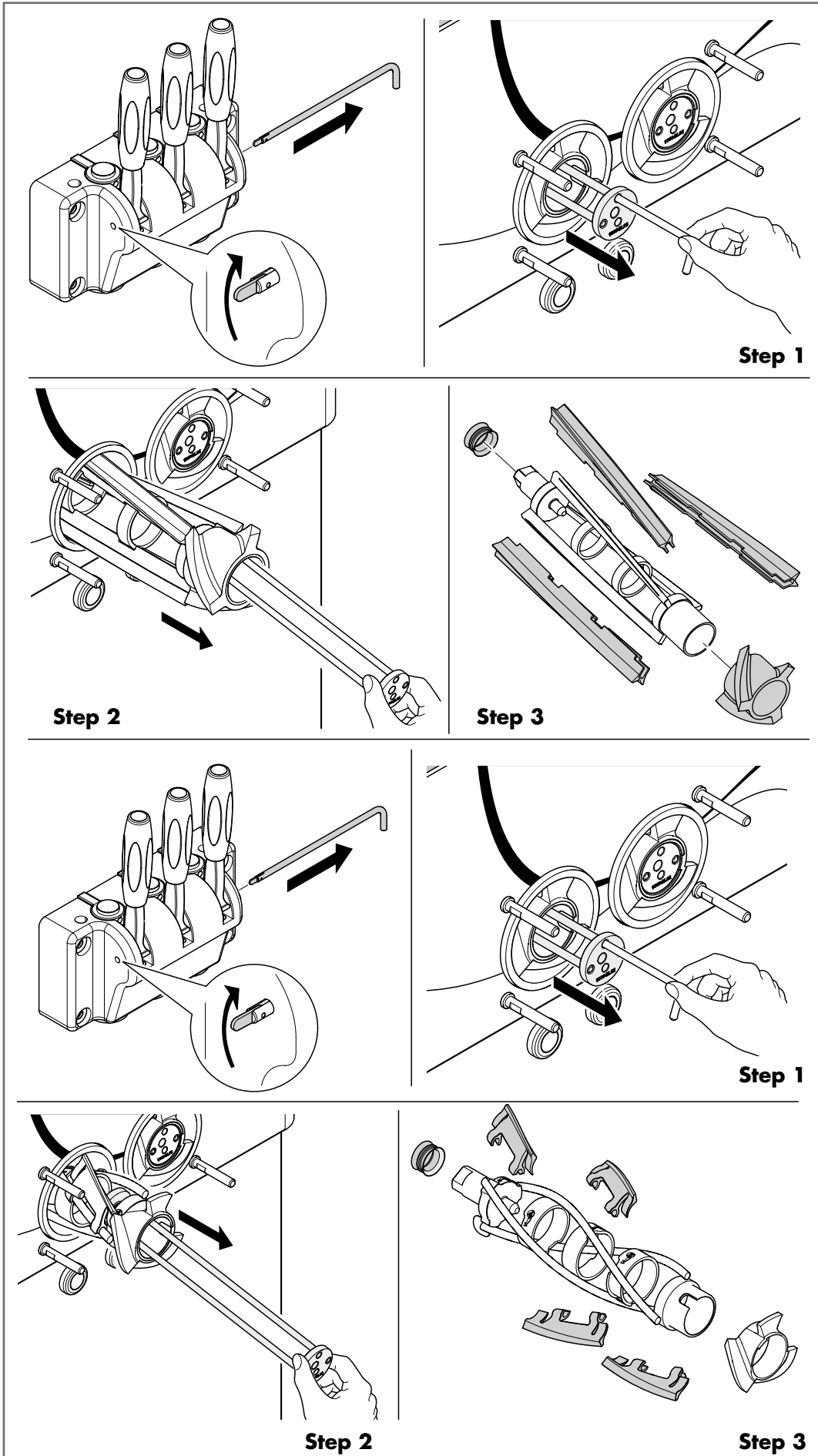

Disassembly of the LS1 beater

Step 1

Use the fastening pin of the dispensing levers to easily extract the counter rotating shaft.

Step 2

Using the counter rotating shaft, extract the beater unit.

Step 3

Remove the sealing gasket, the worm and teflon scrapes.



NOTE

Repeat steps 1-3 for the other beater.

Disassembly of the SF1 beater

Step 1

Use the fastening pin of the dispensing levers to easily extract the counter rotating shaft.

Step 2

Using the counter rotating shaft, extract the beater unit.

Step 3

Remove the sealing gasket, the worm and teflon scrapes.



NOTE

Repeat steps 1-3 for the other beater.

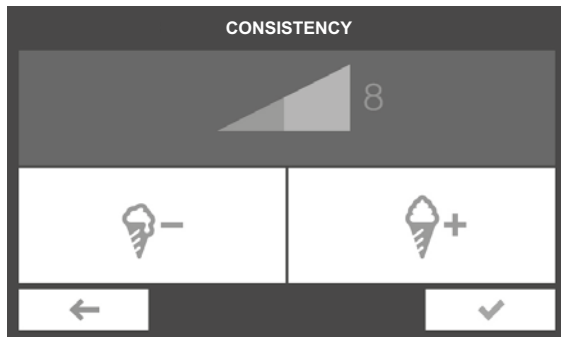

ADJUSTMENTS

Adjusting the ice cream consistency

Use In.Co.Di.S. device to adjust the consistency of your product. A range of 10 values is available.



Step 1

To adjust the product consistency, press key .

Step 2

Press  to reduce the value and so get a softer ice cream.

Press  to increase the value and get a harder ice cream.

Press  to confirm, press  to return to the main menu.

Increase or decrease the values of not more than two units at a time.

Step 3

Wait at least 15 minutes and deliver at least 10 servings before evaluating the new set consistency.

If the setting range does not meet your needs, please contact the dealer to vary the calibration of the machine.

Step 1 Step 2 Step 3

Storage hopper temperature display

The mixture storage temperature inside the hopper is always displayed on the main menu (1).

Step 1

After 60 minutes since the machine start-up, check that the mix temperature in the storage hopper is between 2°C and 4°C (between 36°F and 39°F).



NOTE

In order to avoid rapid deterioration of the mixture, regularly monitor that the storage temperature of the mixture in the hopper is lower than 4° C (39° F). Otherwise, contact a service centre.

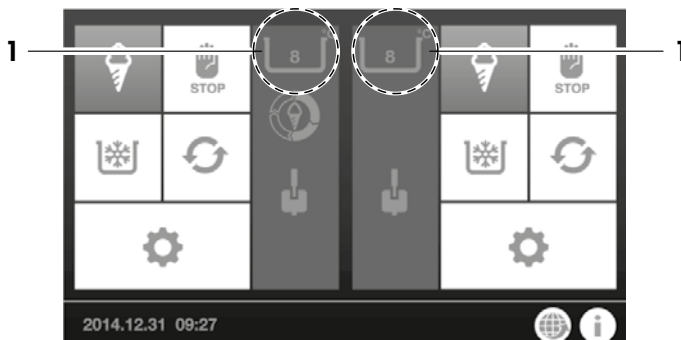

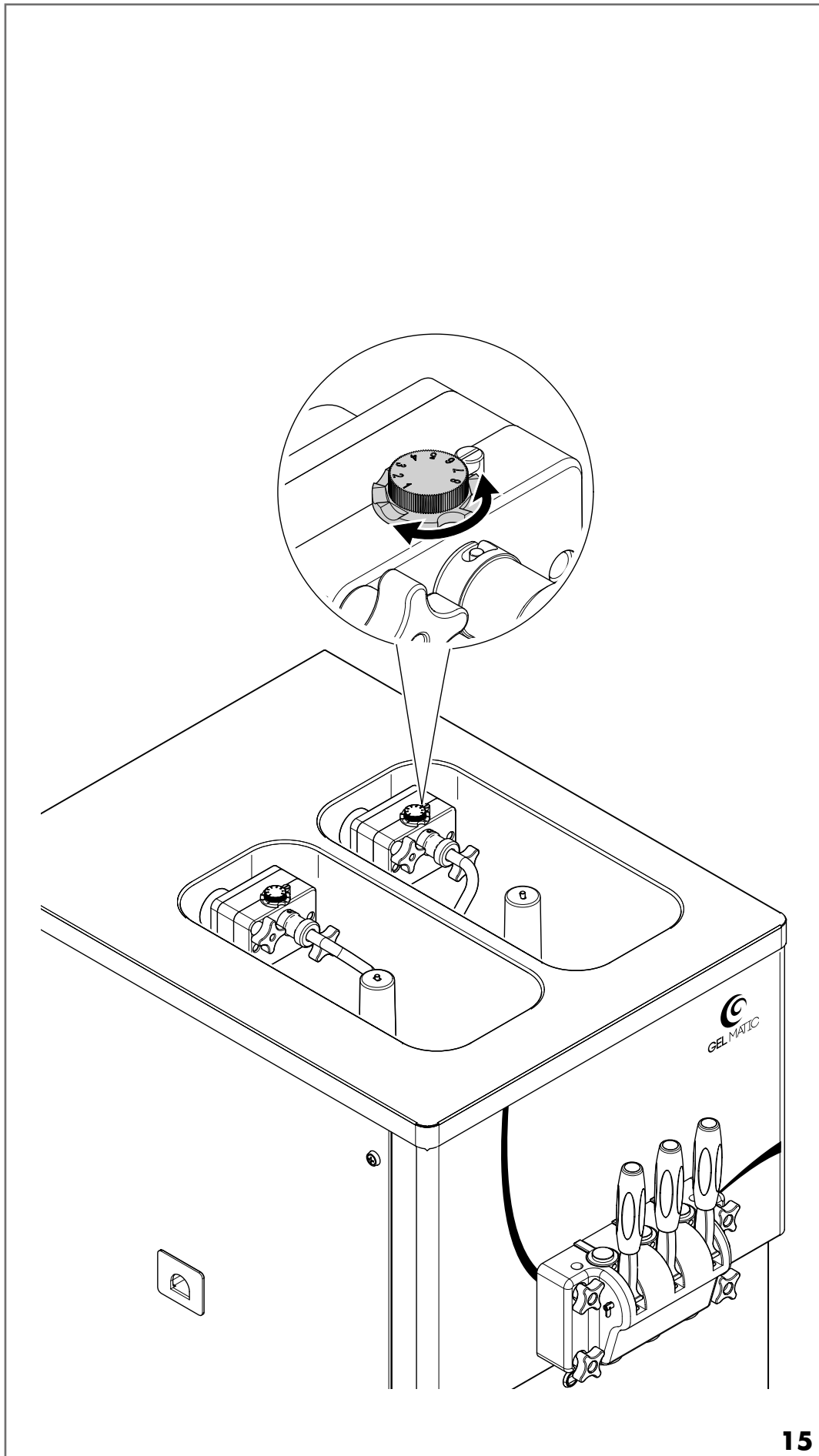

“OVERRUN” adjustment

The pressurizing gear pump allows adjusting the overrun, which is the amount of air present in the dispensed ice cream.

The choice of the overrun percentage varies depending on the mix used: milk-based mix and mix rich in fats have a greater air absorption capacity, and thus the overrun percentage is usually higher than with lean mix, such as frozen yogurt and fruit sorbets, which instead have a poor air absorption capacity.

For the overrun adjustment, rotate and set the ring nut to one of the 8 different positions.

We recommend starting from position 5 and, if necessary, change the setting one value at a time.

For the overrun adjustment, rotate and set the ring nut to one of the 8 different positions.

To increase the percentage of air, rotate the ring nut to lower values (the lower the quantity of mix, the greater the amount of air).

To decrease the overrun, rotate the ring nut to higher values (through the hole passes a greater amount of product, and then the air decreases in proportion).

If the delivered ice cream has a glossy appearance and is not dry and firm, it is necessary to increase the percentage of overrun.

If, during delivery, the ice cream shows clear air bubbles, or the product does not come out in a continuous and constant way, it is recommended to reduce the overrun.

In the event that, while varying the overrun, you can not get a continuous flow, it is necessary to check the fluidity of the product or contact the customer service centre.

6 INSTRUCTIONS FOR USE

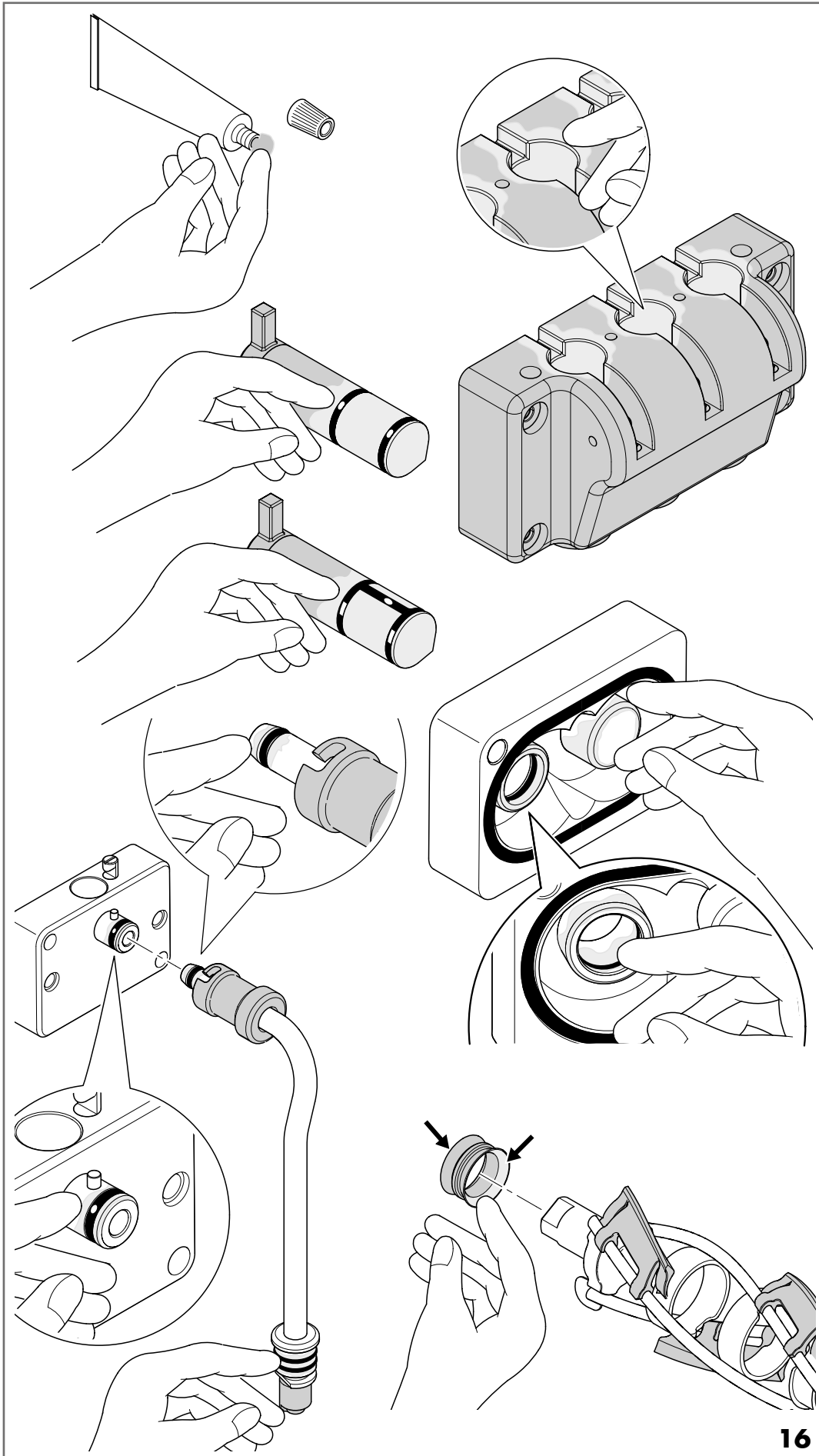

MACHINE LUBRICATION POINTS

Correct and constant lubrication is crucial to keep the machine in perfect condition and at top efficiency.

Lubricate the parts shown in the figure here (**16**) every time you clean the machine.





Always use Haynes Lubri-Film Plus NSF lubricant.

You generally need to lubricate all those points in the machine fitted with gaskets.

16

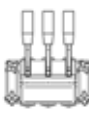

PMP - Preventive Maintenance Program

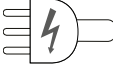
	Description	Months*							
		6	12	18	24	30	36	42	48
	O-ring replacement		■		■		■		■
	Beater scraper replacement		■		■		■		■
	Beater gasket replacement	■	■	■	■	■	■	■	■
For pump-fed units only 	Pump o-ring replacement		■		■		■		■
	Pump gear replacement				■				■
	Cover grinding						■		
	Pump transmission overhaul						■		
	Pump drive belt replacement				■				■
	Pump flow rate check	■	■	■	■	■	■	■	■
	Thorough pump cleaning		■		■		■		■
	RPM sensor check		■		■		■		■
	Transmission components fastening check		■		■		■		■
	For single-phase machines only Motor run capacitor replacement								■
	Air condenser cleaning	■	■	■	■	■	■	■	■
	Gas charge check	■	■	■	■	■	■	■	■
	Fan operation check	■	■	■	■	■	■	■	■
	Copper tube insulation check				■				■
	Relays kit and start and run capacitors replacement								■
	Software update check	■	■	■	■	■	■	■	■
	Electrical board dust cleaning				■				■
	RPM sensor replacement								■
	Temperature probes check	■	■	■	■	■	■	■	■

MAINTENANCE SCHEDULE

At the Gel Matic sales and service centres, it is possible to subscribe a preventive and planned maintenance schedule, in order to extend the efficiency and lifetime of the machine.

This table indicates the operations to be carried out to preserve the correct machine operation. Gel Matic accepts no responsibility for any damage arising from the use of the machine without executing the operations stated.

* The maintenance intervals indicated in this table refer to a machine working 12 months a year.

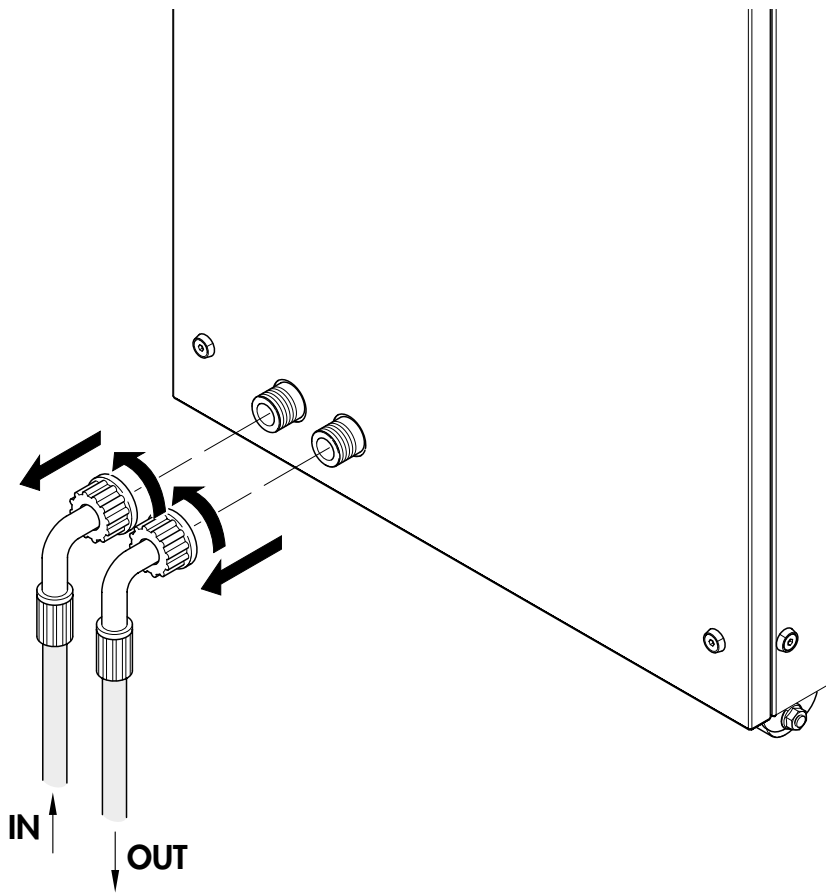

LONG-TERM STORAGE OF THE MACHINE

If you need to store the machine for a long period (e.g. over the winter), make sure that the machine is perfectly clean, sterilized and dry. All removable components should be stored separately.

In the case of water-cooled machines, to avoid problems during storage at the end of the season in rooms where the temperature may fall below freezing 0°C (32°F), you must drain all the water from the condensation circuit.

After closing the inlet tap, remove the hoses and allow all the water in the circuit to drain off (17).

DISPOSAL AT END OF SERVICE

Disposal - WEEE (Waste Electrical and Electronic Equipment).

At the end of its technical and operating life, the machine should be decommissioned, to be no longer used for its intended purpose.

Give the machine to an authorized company for disposal.

 In accordance with European Directive 2002/96/EC, also known as WEEE, the symbol on the product or product packaging indicates that the product should not be disposed of in the normal flow of municipal solid waste.

Instead, it is your responsibility to ensure proper disposal of the machine placed in a separate collection for recycling of electrical and electronic equipment waste.

The collection of this waste helps to optimize the recovery and recycling of reusable materials, while reducing risks to human health and environmental impact.

For more information on proper disposal of the product, contact your local authorities or dealer where you have purchased the machine.

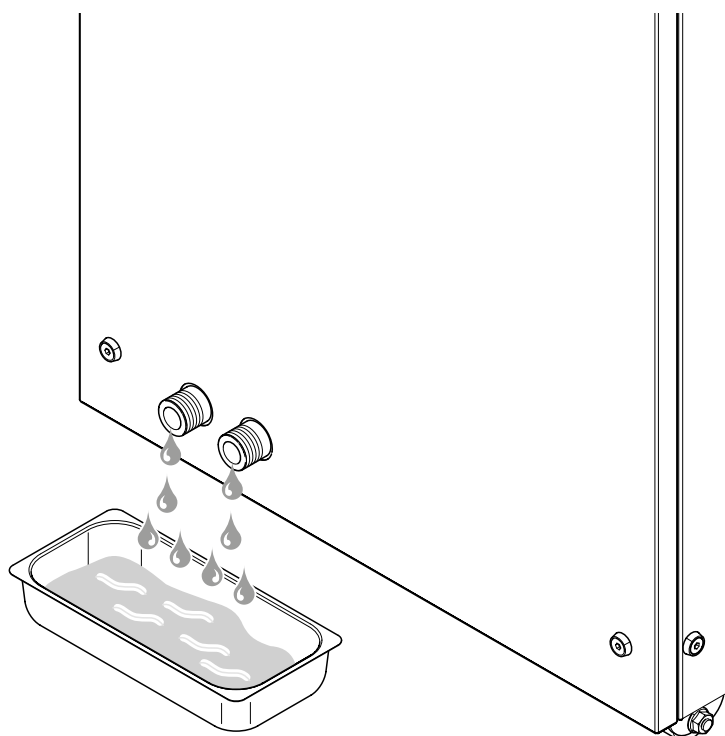

17





Head Office Showroom Production Site
Via Zanica, 6C I - 24050 Grassobbio (BG)

Legal Head Office Production Site
Via G. Galilei, 10 I - 24050 Orio al Serio (Bg)

Tel. +39 035 525138
info@gelmatic.com - www.gelmatic.com