

PFC SERIES MODELS

VENTLESS/HOODLESS COUNTERTOP DEEP FRYER

Advanced by Design



- SELF VENTING
- ODORLESS
- HEPA STYLE AIR FILTRATION
- INTEGRAL FIRE SUPPRESSION
- PROGRAMMABLE CONTROLS
- EASY TO CLEAN
- SMALL FOOTPRINT
- LARGE OUTPUT
- MODULAR DESIGN



Available at:



1-800-263-1455

www.perfectfry.com

The Benchmark in Ventless Deep Frying



P/N 83718 Rev B (2/21)

CLEARANCES

1" all around and 0" on top.

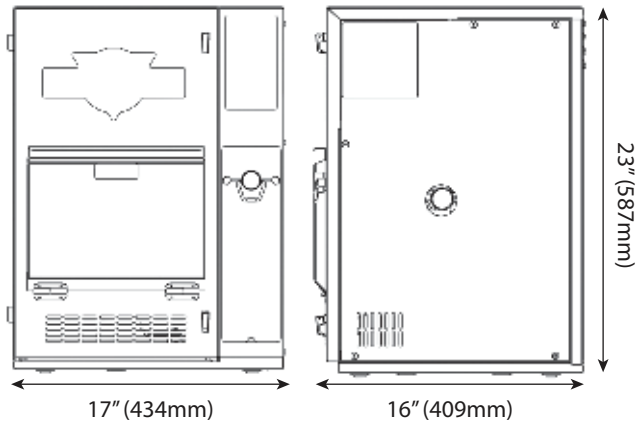

AIRFLOW DIAGRAM

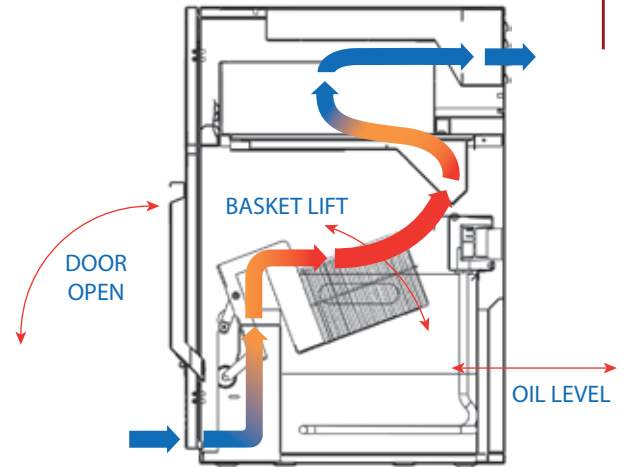

SPECIFICATIONS TABLE

MODEL	PFC570	PFC375	PFC570	PFC187
Power Supply (volts) ¹	240	240	208	120
Current (amps)*	24	16	27	16
Cord Option	8/3 Power Cord, NEMA 6-50 Plug	8/3 Power Cord, NEMA 6-50 Plug	8/3 Power Cord, NEMA 6-50 Plug	10/3 Power Cord, NEMA 5-20 Plug
Power (kilowatts)	5.7	3.8	5.7	1.9
Capacity (lb/hr)‡**	60	45	60	30

BASKETS

OPTIONAL BASKET COVER
(ordered separately
part no. 6HT002)

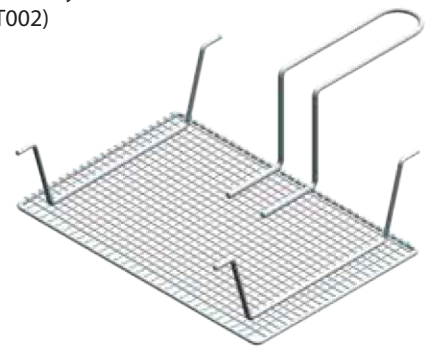

GENERAL SPECIFICATIONS

All Models

Cycles	60 Hz
Weight	80 lbs (36 kg)
Shipping Weight	95 lbs (43 kg)
Shipping Dimensions	Depth 22" (559 mm) Width 22" (559 mm) Height 27" (686 mm)
Shipping Cube	7.56 ft ³ (.214 m ³)
Oil Capacity	2 US Gallons (8 L)
Construction	304 Stainless Steel

** Using 1 1/2 minute fast fries

*** Locking cabinet option also available

EXTRA LARGE
(32oz/6 servings)

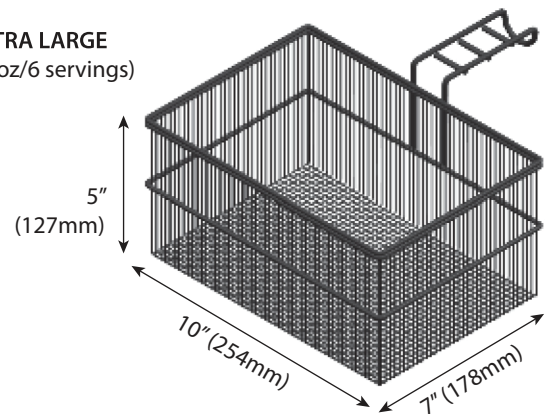

SPECIFICATIONS SUBJECT TO CHANGE WITHOUT NOTICE.