

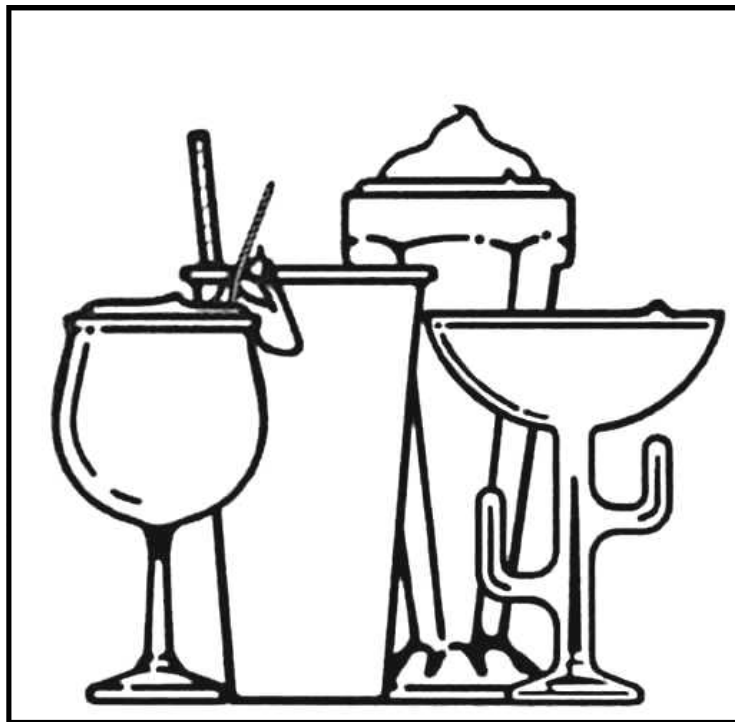

“Reliability from the team that Serves the Best”



**Frozen Beverage Dispensers
Models 707, 708, 709, 724, 791, 798**

Operation Manual

SaniServ P.O. Box 1089 Mooresville, Indiana 46158

Free Training Video Available Online

This informative video will show you how to properly operate your SaniServ Frozen Beverage machine.

Topics Covered:

Assembly & Lubrication
Sanitization & Charging
Disassembly & Cleaning
Maintenance Parts



<http://fb.saniserv.com>

Training videos are also available for purchase in DVD format. Please contact your local SaniServ distributor for more information.

Distributor Name: _____

Address: _____

Phone: _____

Date of Installation: _____

Model Number: _____

Serial Number: _____

Installer/Service Technician: _____

SERVICE: Always contact your SaniServ dealer or distributor for service questions or service agency referral. If your SaniServ dealer or distributor cannot satisfy your service requirements, he is authorized to contact the factory for resolution.

Note: It is the Owner's responsibility to maintain the Service Record located on the inside rear cover of this manual. An accurate record of service performed can greatly expedite troubleshooting of problems and significantly reduce repair costs.

PARTS: Always order parts from your SaniServ dealer or distributor. When ordering replacement parts, specify the part numbers, give the description of the part, the model number and the serial number of the machine.

WARRANTY: Remove the Check Test Start (CTS) form and fill it out in its entirety. Return the original (white) copy to SaniServ. The Dealer/Distributor retains the second (yellow) copy and the Owner/Operator retains the third (pink) copy.

The Manufacturer's Limited Warranty is printed on the reverse side of the Owner/Operator copy.

TO VALIDATE THE WARRANTY, THE CTS FORM

IMPORTANT

MUST BE COMPLETED AND RETURNED TO THE FACTORY WITHIN 30 DAYS OF INSTALLATION.

Note: The Check Test Start function must be performed by a qualified technician.

IMPORTANT

This machine was designed to produce frozen slush beverages only.

Do NOT attempt to operate this machine with softserve or shake type product mix.

Damage to the machine may occur and warranty will be void.

NOTICE

This SaniServ manual has been developed in a format which complies with CE guidelines at the time of publication. Reference is made to 50 cycle units, but this manual applies to machines of all electrical power configurations.

STATEMENT OF INTENDED USE

All SaniServ Machines covered in this manual are designed for one specific end use - to freeze and dispense frozen beverages.

PICTOGRAM LEGEND

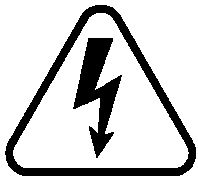

ELECTRICAL SHOCK HAZARD



TIP AND CRUSH HAZARD

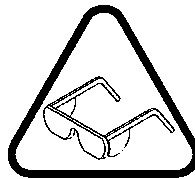

PROTECT EYES



HAND PINCH OR ENTRAPMENT HAZARD



SHARP MACHINE PARTS HAZARD



CLEANOUT OPERATION



FROZEN PRODUCT

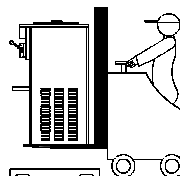

USE MECHANICAL LIFT EQUIPMENT

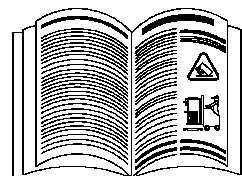

READ AND UNDERSTAND

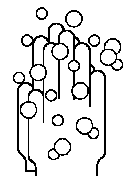

WASH HANDS BEFORE PROCEEDING

IMPORTANT

This machine was designed to produce frozen slush beverages only.

Do NOT attempt to operate this machine with softserve or shake type product mix.

Damage to the machine may occur and warranty will be void.

Table of Contents

Introduction and Installation.....	1
Installer's Preoperational Check.....	2
Disassembly and Cleaning.....	3
Assembly and Lubrication.....	7
Sanitizing.....	10
Operation (Filling and Starting).....	11
Helpful Hints.....	12
Consistency Adjustment.....	13
Routine Maintenance.....	14
Troubleshooting Guide.....	15
Troubleshooting Glossary.....	16
Service Record.....	17

Illustrations

Fig. 1	Leg Installation.....	1
Fig. 2	Control Switch.....	2
Fig. 3	Do Not Insert Objects!.....	3
Fig. 4	Control Switch.....	3
Fig. 5	Dispensing Product.....	3
Fig. 6	Control Switch.....	4
Fig. 7	Dispensing Product.....	4
Fig. 8	Front Plate Assembly.....	4
Fig. 9	O-Ring Removal.....	4
Fig. 10	Dasher Assembly.....	5
Fig. 11	Scraper Blade Removal.....	5
Fig. 12	Drip Tray Assembly.....	5
Fig. 13	Cleaning ALL Ports and Holes.....	6
Fig. 14	Dasher Lubrication.....	7
Fig. 15	Dasher Assembly.....	7
Fig. 16	Scraper Blade Installation.....	8
Fig. 17	Scraper Blade Installation.....	8
Fig. 18	Scraper Blade Wear Mark.....	8
Fig. 19	Dasher Installation.....	8
Fig. 20	Dasher Installation.....	8
Fig. 21	Dasher with Blade (Front View).....	9
Fig. 22	Spigot Plunger Lubrication.....	9
Fig. 23	Front Plate Assembly.....	9
Fig. 24	Drip Tray Assembly.....	9
Fig. 25	Control Switch.....	10
Fig. 26	Do Not Insert Objects!.....	10
Fig. 27	Dispensing Product.....	11
Fig. 28	MIXOUT Light.....	11
Fig. 29	Water-Cooled Condenser Valve.....	12
Fig. 30	Wiring Box.....	13
Fig. 31	Electronic Consistency Control.....	13
Fig. 32	Scraper Blade Wear Mark.....	14
Fig. 33	Clean Sharp Condenser Fins.....	14

Introduction

This manual provides a general system description of the SaniServ Frozen Beverage Dispensers. It has been prepared to assist in the training of personnel on the proper installation, operation, and maintenance of the machines.

Read and fully understand the instructions in this manual before attempting to install, operate, or perform routine maintenance on the machines.

The following sections of the manual must be performed in sequence:

1. Installation
2. Installer's Preoperational Check
3. Disassembly & Cleaning
4. Assembly & Lubrication
5. Sanitizing & Operation
6. Consistency Adjustment

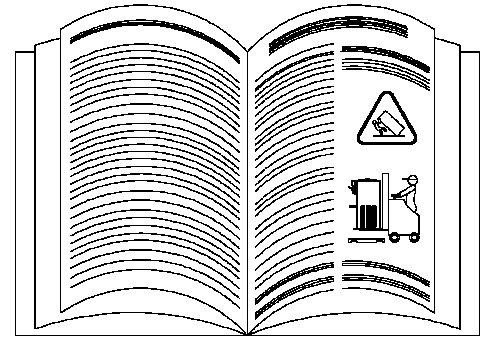

Installation



WARNING

ALWAYS USE A SUFFICIENT NUMBER OF PEOPLE OR MECHANICAL LIFTING EQUIPMENT TO PROTECT ALL PERSONNEL FROM PERSONAL INJURY DURING THE REMAINING STEPS.

1. Raise the machine to install the four legs packed in the mix pan or the four casters packed in a box on the skid or on the front mounted drip tray. **Be certain all four are tight! Thread lock is suggested.**
2. Carefully lower the machine to the floor and place it where it will be installed.
3. Level the unit by turning the bottom part of each leg clockwise or counterclockwise (Fig. 1). The machine **MUST** be level to operate properly.

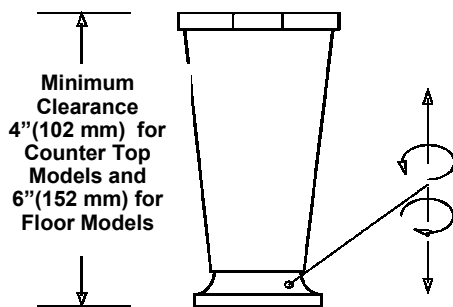

Fig. 1

THESE UNITS MUST NOT BE OPERATED WITHOUT LEGS INSTALLED OTHERWISE BOTTOM AIRFLOW TO THE CONDENSER WILL BE RESTRICTED.

A MINIMUM 6" (152 MM) CLEARANCE MUST BE MAINTAINED AT THE REAR AND SIDES OF THE MACHINE FOR ADEQUATE VENTILATION.

4. Electrical and refrigeration specifications are located on the data plate on the rear of the individual machines. Consult local authorities for information regarding plumbing and electrical codes in the area.

Note: All SaniServ machines should have their own dedicated circuits whether they are cord connected plug-in devices or hard wired units.

IMPORTANT

ALWAYS CHECK ELECTRICAL SPECIFICATIONS ON THE DATA PLATE OF THE MACHINE. DATA PLATE SPECIFICATIONS ALWAYS SUPERSEDE ELECTRICAL INFORMATION IN THIS MANUAL.

5. The water line connections on water-cooled machines are located on the back side of the machine. The **IN/OUT** lines are clearly marked and have 1/4" male pipe threads fitted with a 3/4" garden hose fitting.

Note: These water lines are installed on water-cooled machines only.

FAILURE TO PROVIDE FOR PROPER EARTH GROUND ACCORDING TO LOCAL ELECTRICAL



WARNING

CODES COULD RESULT IN SERIOUS ELECTRICAL SHOCK OR DEATH. DO NOT USE EXTENSION CORDS. INSTALL THE PROPER SIZE WIRE FOR THE REQUIRED MACHINE AMPS. BE CERTAIN TO OBSERVE LOCAL CODES IN SELECTING WIRE OR CORD SIZE AND TYPE.

DO NOT TURN MACHINE ON UNTIL THE INSTALLER'S PRE-OPERATIONAL CHECK SECTION IS COMPLETE.

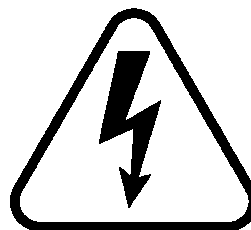

Installer's Preoperational Check

THE FOLLOWING ITEMS MUST BE PERFORMED BEFORE ATTEMPTING TO OPERATE THE EQUIPMENT:



WARNING

1. Make certain that proper electrical connections have been made. Plug power cord into power outlet.
2. Set each control switch (Fig. 2) to the "CLEANOUT" position momentarily to verify the direction of rotation of the dasher. Looking at the front of the machine, the dasher should rotate counter-clockwise.
3. Set each control switch to the "OFF" position.

In the event the dasher turns clockwise, **STOP** and do not proceed any further. On three-phase units, reverse the polarity.

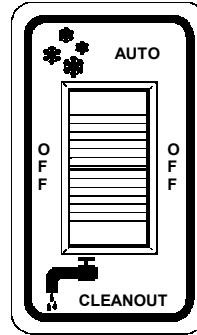

Fig. 2
Control Switch



CAUTION

UNDER NO CIRCUMSTANCES SHOULD THE UNIT BE OPERATED IN THE "AUTO" POSITION FOR MORE THAN THREE MINUTES WITH EMPTY FREEZING CYLINDERS. DOING SO WILL RESULT IN DAMAGE TO THE MACHINE.

IMPORTANT

A MINIMUM OF 6" (152 MM) CLEARANCE MUST BE MAINTAINED AT THE REAR AND SIDES OF THE MACHINE FOR ADEQUATE VENTILATION.

IMPORTANT

This machine was designed to produce frozen slush beverages only.

Do NOT attempt to operate this machine with softserve or shake type product mix.

Damage to the machine may occur and warranty will be void.

Disassembly and Cleaning

CONSULT YOUR LOCAL HEALTH AGENCY FOR LOCAL CLEANING AND SANITIZING REQUIREMENTS.

This unit does not come pre-sanitized from the factory. Before serving product, the dispenser must be disassembled, cleaned, lubricated, and sanitized. Please be aware that these instructions are general guidelines. Cleaning and sanitizing procedures must conform to local Health Authority requirements.

Emptying Machine

Prior to the disassembly and cleaning of parts, the machine must be emptied of product. Use the following procedures (Steps 1 through 3). If this is first time operation, disregard these steps.



CAUTION

DO NOT INSERT ANY OBJECTS OR TOOLS (FIG. 3) INTO THE MIX INLET HOLE, RESTRICTOR TUBE HOLE, OR FRONT PLATE DISPENSING HOLE WHILE THE MACHINE IS RUNNING. DAMAGE TO THE MACHINE OR PERSONAL INJURY MAY RESULT

1. Set the control switch (Fig. 4) to the “CLEANOUT” position and dispense all product from the freezing cylinder by pulling downward on the spigot handle (Fig. 5) to empty the machine.
2. Set the control switch (Fig. 4) to the “OFF” (center) position. Close the spigot handle (Fig. 5) before proceeding to cleaning.

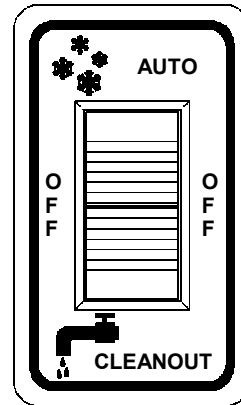

Fig. 4
Control Switch

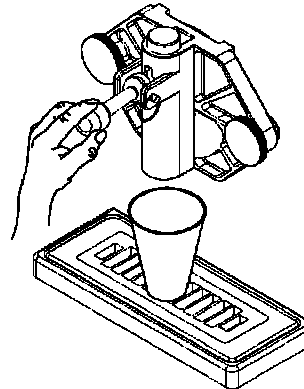

Fig. 5
Dispensing Product

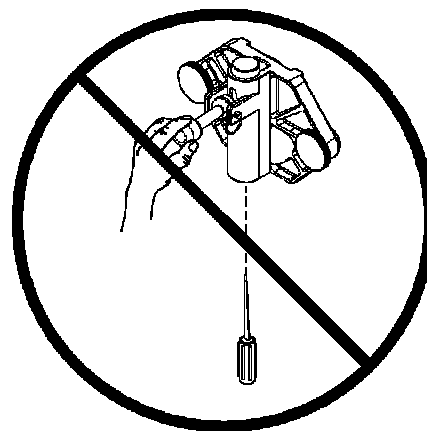
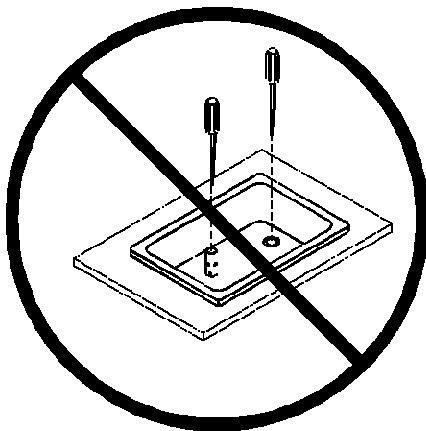

Fig. 3
Do Not Insert Objects or Tools

Disassembly and Cleaning Procedure

1. Fill the machine with cold water and set each control switch (Fig. 6) to the “**CLEANOUT**” position. **DO NOT** use hot water which could damage the machine. Let the machine agitate 1 to 2 minutes, then drain the water by pulling downward on the spigot handle (Fig. 7). Repeat the above procedure as necessary to make certain all product is removed from the machine. After the machine is empty, set the control switch to the “**OFF**” position.

2. Prepare a suitable detergent and water solution at a temperature of approximately 125°F. (52°C.) to 130°F. (55°C.). For best cleaning results select a concentrated anti-bacterial dishwashing detergent containing biodegradable anionic and nonionic surfactants. **Avoid detergents containing phosphates. DO NOT** use an abrasive detergent on any part of the dispenser. **DO NOT USE HOT WATER.**



CAUTION

DOING SO MAY DAMAGE THE MACHINE.

3. Make certain that the machine is “**OFF**”. Fill the mix pan with the cleaning solution. Clean the mix pan thoroughly with a brush as the solution drains into the freezing cylinder(s). Clean the mix inlet tube(s) and the restrictor tube holes with the brush provided.

4. Set the control switch (Fig. 6) to the “**CLEANOUT**” position and agitate for approximately 1 to 2 minutes and then drain the water by pulling down on the spigot handle (Fig. 7). After the unit is empty, set each control switch to the “**OFF**” position.

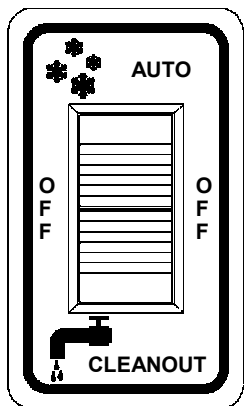

Fig. 6
Control Switch

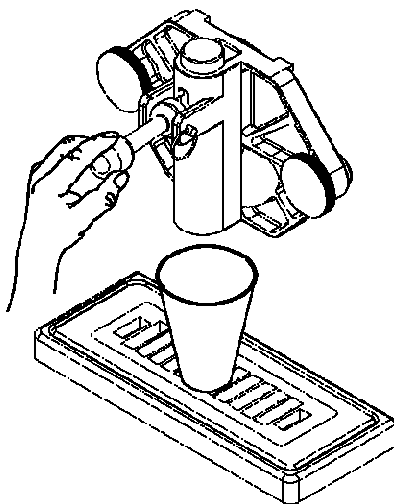

Fig. 7
Dispensing Product



CAUTION

DO NOT USE ANY TOOLS OR SHARP OBJECTS TO REMOVE ANY O-RINGS FROM THIS MACHINE. SHARP OBJECTS WILL DAMAGE THE O-RINGS.

5. Remove the front plate by turning the black plastic knobs in a counterclockwise direction (Fig. 8). Disassemble the front plate in the following manner:

- Remove the faspin and spigot handle.
- Remove the front plate o-ring.
- With the spigot handle removed, push the spigot plunger out the top of the front plate and remove all lubricant from the spigot plunger.
- Remove the o-rings from the spigot plunger by grasping the part with one hand and with a dry cloth in the other hand, squeeze the o-ring upward. When a loop is formed, grasp the o-ring with the other hand and roll it out of its groove and off the spigot plunger (Fig. 9).

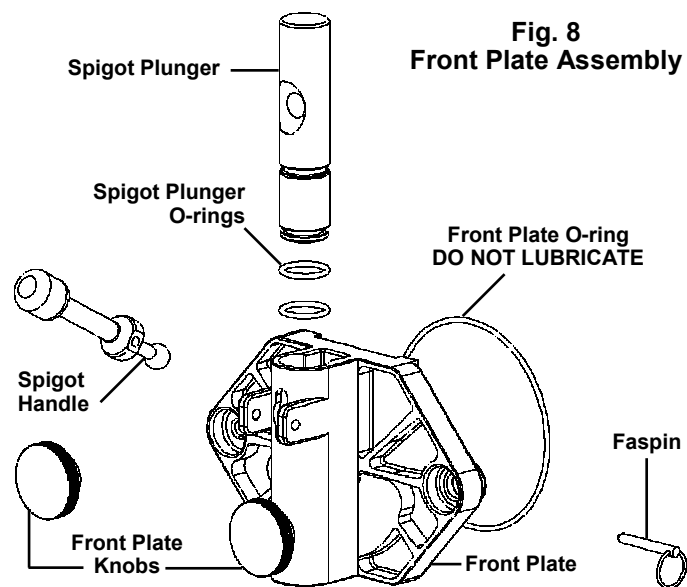

Fig. 8
Front Plate Assembly

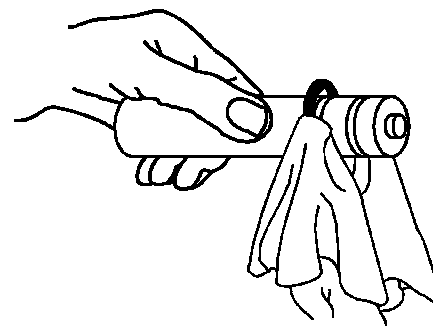

Fig. 9
O-Ring Removal

9. Remove the dasher assembly (Fig. 10) being careful not to damage the scraper blades, then disassemble in the following manner:

- a. Remove and take apart the rear seal assembly.
- b. Remove the stator rod from the dasher.
- c. Remove the blades from the dasher (Fig. 10) by first rotating blade upward (Fig. 11) and then unsnapping one end from the support rod.

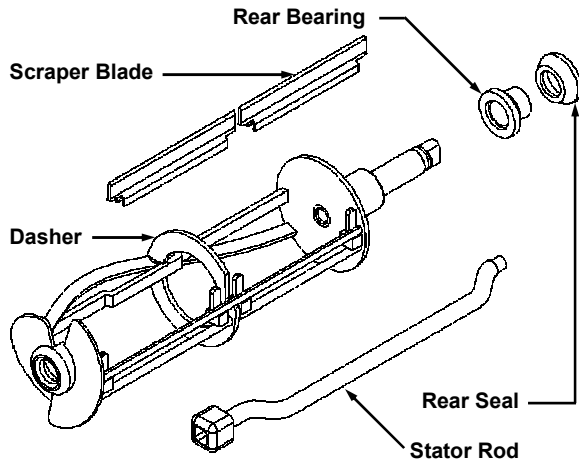

Fig. 10
Dasher Assembly

BLADES MUST BE REMOVED FOR CLEANING

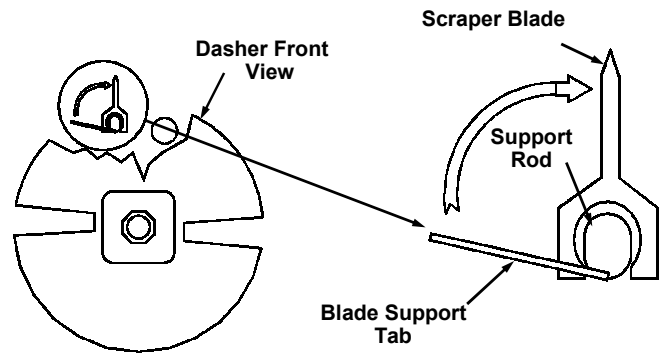
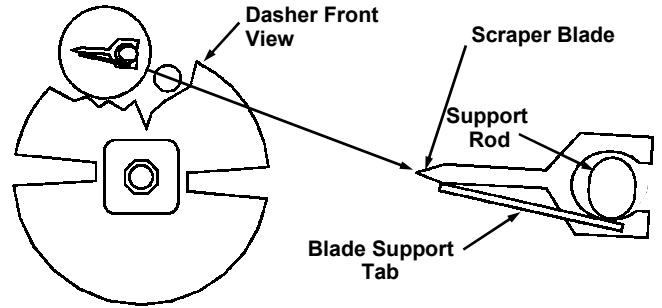

Fig. 11
Scraper Blade Removal

10. Remove the mix pan lid, drip tray and drip tray

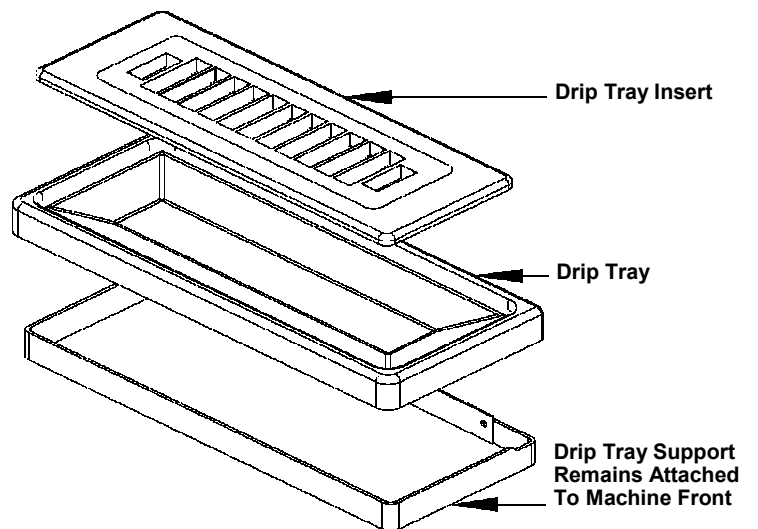



Fig. 12
Drip Tray Assembly

11. For best cleaning results select a concentrated anti-bacterial dishwashing detergent containing biodegradable anionic and nonionic surfactants.
NOTE: Avoid detergents containing phosphates.
WEAR SAFETY GLASSES - DO NOT SPLASH

 **CAUTION**

DETERGENT SOLUTION IN EYES

Be certain to follow the manufacturer's mixing instructions when adding the dishwashing detergent concentrate to water.

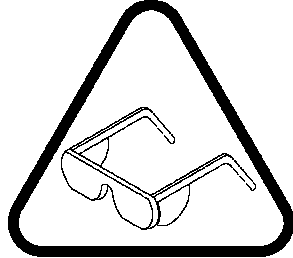

12. Place all parts in a three partition sink filled with the following solutions:

- a. In one partition, detergent solution diluted to the manufacturer's suggested concentration for use.
- b. In a second partition, clear rinse water.
- c. In a third partition, sanitizing rinse solution which will produce a 200 parts per million (PPM) Chlorine residual or whatever Chlorine residual is required by your Local Health Authority.

13. Use the brushes to clean all holes and ports in the parts (Fig. 13).

 **CAUTION**

DO NOT use an abrasive detergent

14. After thoroughly washing the parts in the detergent solution, rinse them in the clear rinse water. Place the parts in the sanitizing solution for at least five minutes or whatever your Local Health Authority requires, and then air dry the parts before for assembly and lubrication.

DO NOT ALLOW THE PARTS TO SOAK IN

 **CAUTION**

SANITIZER FOR SEVERAL HOURS.
DO NOT WIPE THE PARTS DRY - AIR DRY ONLY.

15. The remainder of the machine including the mix pan and freezing cylinder must be cleaned in place using a mild detergent solution followed by a clear rinse. Clean the exterior with a damp cloth.
DO NOT use an abrasive cleaner on the exterior of the machine or on any of the panels (guards).

WHEN CLEANING THE MACHINE, DO NOT ALLOW

 **WARNING**

EXCESSIVE AMOUNTS OF WATER AROUND ANY ELECTRICALLY OPERATED COMPONENTS OF THE MACHINE. ELECTRICAL SHOCK OR DAMAGE TO THE MACHINE MAY RESULT.

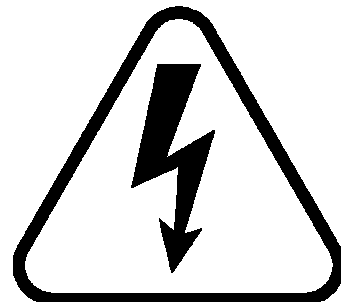
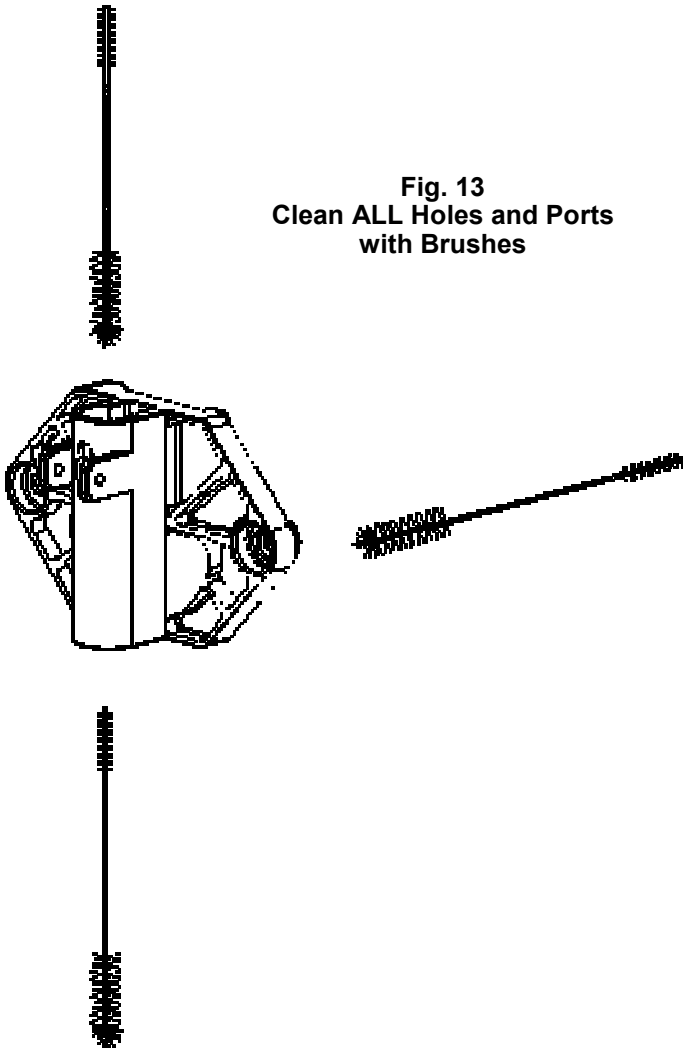

Fig. 13
Clean ALL Holes and Ports with Brushes



Assembly and Lubrication

Use a food grade lubricant* ONLY. SaniServ part number 1150 is recommended and is available from the factory or your local authorized SaniServ dealer or distributor. **Lubrication must be performed daily.**

* The SaniServ recommended product is a colorless to white, odorless, tasteless food contact lubricant accepted by the United States Food and Drug Administration (FDA) with a USDA rating of H1 and certified for food contact by NSF International. Its useful temperature range is -15°F - 210°F (-26°C - 99°C) with a melt point of 93°C using ASTM D566 and a Saybolt viscosity of 55 at 210°F (99°C) when measured using ASTM D445

1. Lubricate and assemble the dasher assembly in the following manner:

- a. Apply a generous amount of lubricant to the shoulder of the dasher and the area of the shaft where the white plastic portion of the assembled rear seal contacts the shaft (Fig. 14). This is easily performed by running a 1/4" (6 mm) bead of lubricant around the shoulder of the dasher.
- b. Lubricate the two areas of the stator rod (Fig. 14) and slide the stator rod into the dasher (Fig. 15). Make certain that the end of the stator rod is inserted into the hole at the rear of the dasher.

- c. Assemble and install the rear seal with the rubber portion toward the rear of the freezing cylinder as indicated in Fig. 15.



CAUTION

DO NOT LUBRICATE THE RUBBER PORTION OF THE REAR SEAL. LUBRICATION ON THE REAR SEAL WILL DAMAGE THE MACHINE.

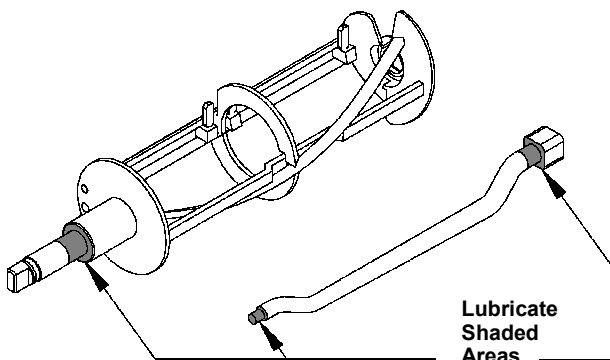

Fig. 14
Stator Rod and Dasher Lubrication

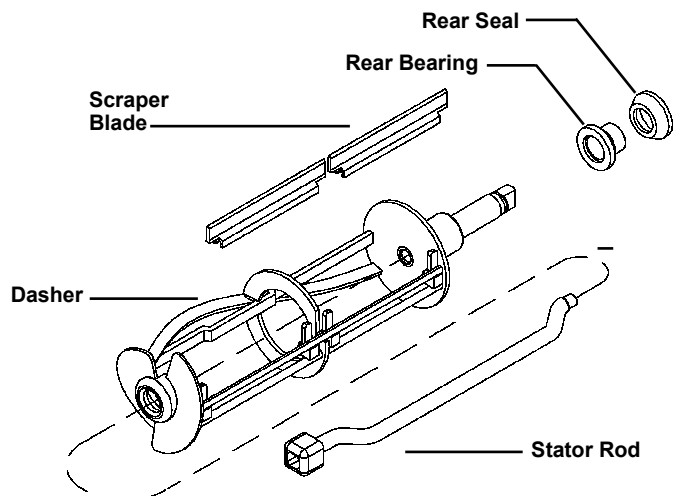

Fig. 15
Dasher Assembly

- d. Install the scraper blades onto the dasher assembly by holding the blades perpendicular to the tabs (Fig. 16) and then snapping them over the flat area of the support rod. Then rotate the blades downward in a counterclockwise direction as viewed from the front of the dasher (Fig. 17). **BE CERTAIN THAT THE SCRAPER BLADES REST UPON THE DASHER TABS.**

Note: Reverse the blades at each cleaning to maintain sharpness. In addition, the blades are equipped with a wear mark (Fig. 18). When the blade is worn to this wear mark, it must be replaced.

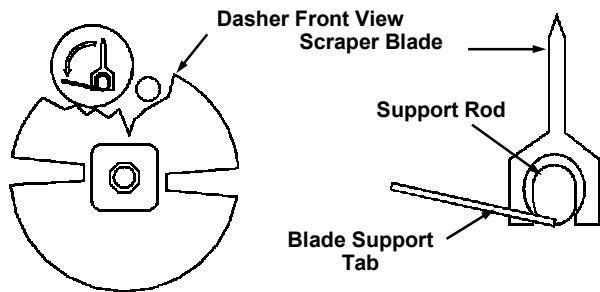

Fig. 16
Scraper Blade Installation

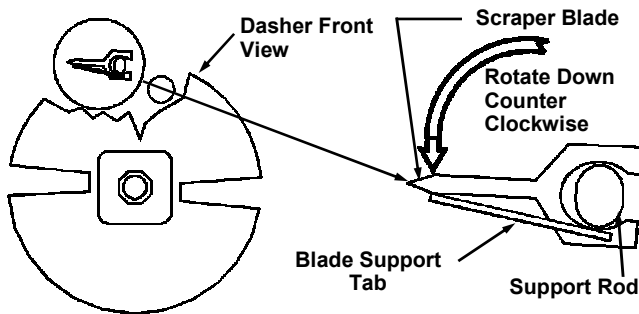

Fig. 17
Scraper Blade Installation

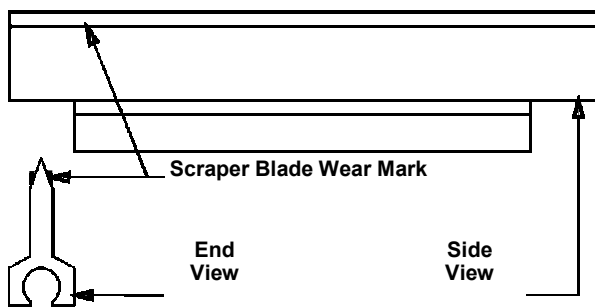
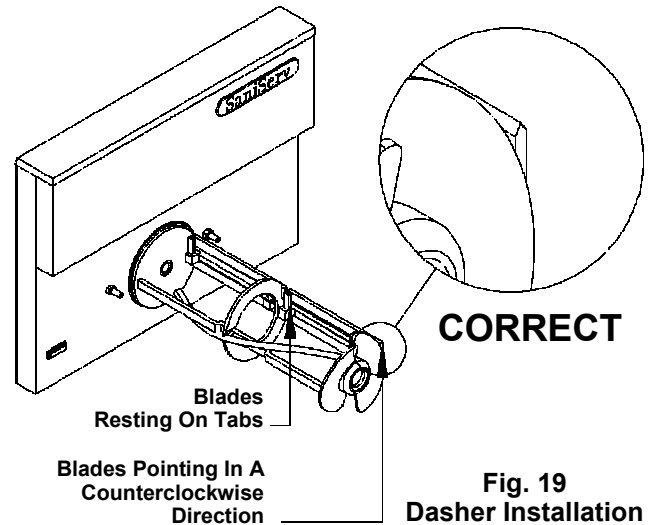

Fig. 18
Scraper Blade Wear Mark

- e. Insert the dasher assembly into the freezing cylinder as far as possible (Fig. 19) being careful not to damage the scraper blades. Damage will occur to the scraper blades and the dispenser will not operate properly if the scraper blades are installed facing in a clockwise direction (Fig. 20).



Note: The stator rod has been deleted from Fig. 19 and

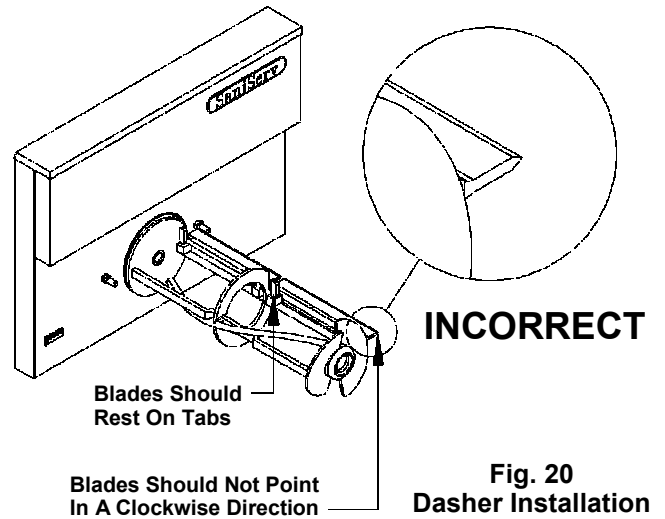

Fig. 20 for clarity only. The stator rod must be installed for proper machine operation.

- f. While maintaining force against the dasher, rotate it slowly until the tongue of the dasher engages the groove in the drive system at the rear of the cylinder. The outer most portion of the dasher should be recessed approximately 1/4" (6 mm) to 3/8" (10 mm) inside the freezing cylinder. No part of the dasher should extend outside the cylinder. Scraper blades should be visible, extending approximately 1/8" (3 mm) beyond the dasher (Fig. 21).

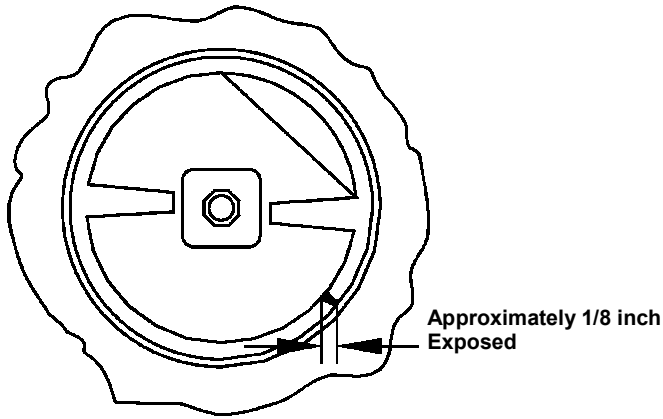

Fig. 21
Dasher with Blade (Front View)

2. Lubricate and assemble the front plate assembly in the following manner:

- a. Install the two o-rings on the spigot plunger by rolling them onto the plunger. Seat the o-rings in the grooves. Be certain that they are not twisted. Smooth the lubricant into the grooves and over the sides of the plunger assembly (Fig. 22).

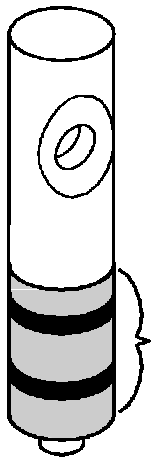

Fig. 22
Spigot Plunger Lubrication

- b. Slide the lubricated spigot plunger into the front plate (Fig. 23) making certain that the spigot handle slot is aligned to the front.
- c. Insert the spigot handle and secure with the faspin.
- d. Install the front plate o-ring.

DO NOT LUBRICATE THE FRONT PLATE O-RING

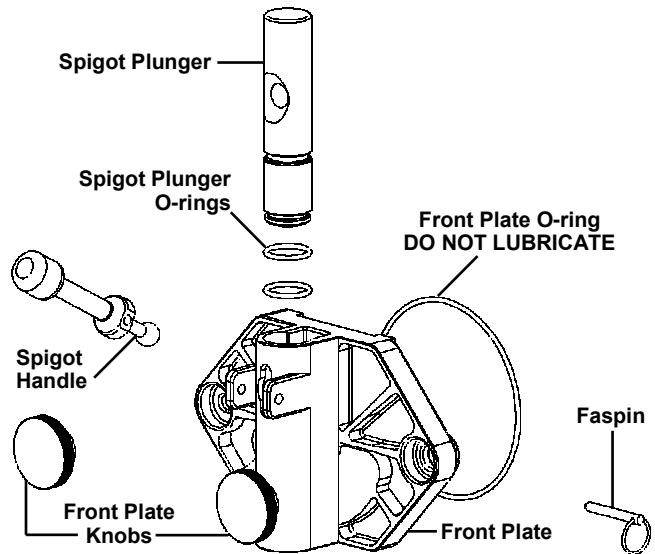

Fig. 23
Front Plate Assembly

- e. Secure the front plate assembly with the two plastic knobs. Simultaneously, turn the knobs in a clockwise direction. Tighten the knobs evenly. **DO NOT** tighten one knob all the way down and then the other. Doing so may result in front plate breakage. Only moderate force is required. **DO NOT** over tighten. Close the spigot plunger.
3. Install the drip tray and drip tray insert (Fig. 24).
4. Proceed to the “**Sanitizing**” section of this manual.

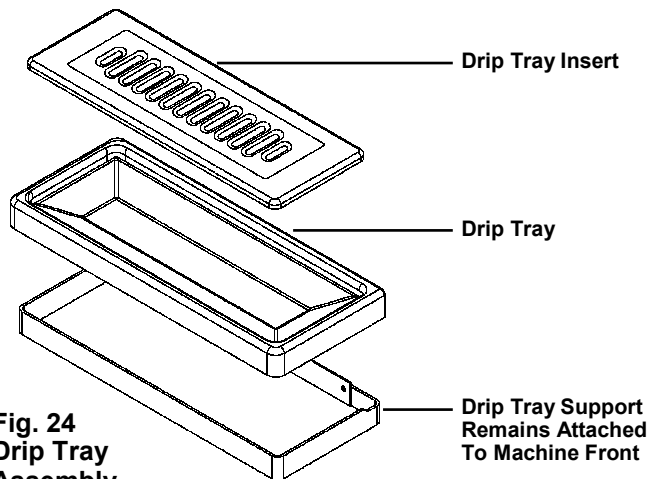

Fig. 24
Drip Tray
Assembly

Sanitizing

Prior to operation, the machine must be sanitized. The unit must have already been cleaned and lubricated.

Note: Sanitize immediately before use, not several hours before or the previous evening.

1. First, wash hands with a suitable antibacterial hand soap. For best results select a concentrated anti-bacterial hand soap containing biodegradable anionic and nonionic surfactants.

2. Prepare approximately 2 to 3 gallons (8 to 12 liters) of sanitizing solution equivalent to 200 ppm chlorine residual or the residual required by your local health agency.

3. Carefully pour the solution into the mix pan.

4. Using a sanitary brush, wipe the solution onto the sides of the mix pan, over the mixout probe in the bottom of the mix pan, and the underside of the mix pan lid.

5. Set the control switch (Fig. 25) to the "CLEANOUT" position and let the unit agitate for approximately three to five minutes.

NOTE: DO NOT set the control switch to the "AUTO" position. Doing so would freeze the sanitizing solution and may result in damage to the machine.

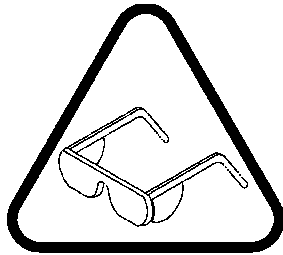
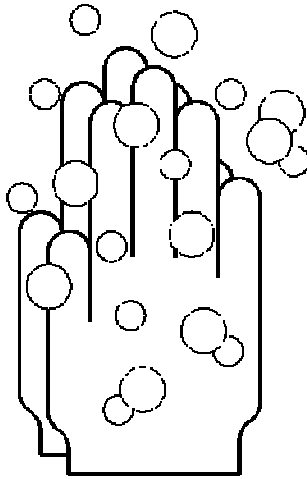

WARNING

DO NOT INSERT ANY TOOLS OR OBJECTS INTO THE MIX INLET HOLE, RESTRICTOR TUBE HOLE, OR THE DISPENSING HOLE IN THE FRONT PLATE. DAMAGE TO THE MACHINE OR PERSONAL INJURY MAY RESULT (FIG. 26)

6. Set the control switch to the "OFF" position and drain the solution from the machine. Proceed directly to the "Operation" section of this manual.

WARNING

DO NOT RINSE OUT THE MACHINE.

DO NOT ALLOW SANITIZING SOLUTION TO REMAIN IN THE MACHINE FOR SEVERAL HOURS. DOING SO COULD DAMAGE THE MACHINE.

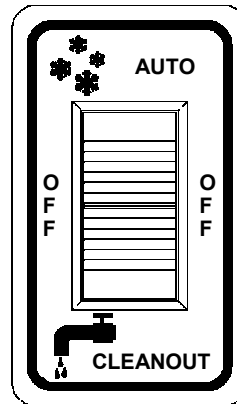

Fig. 25
Control Switch

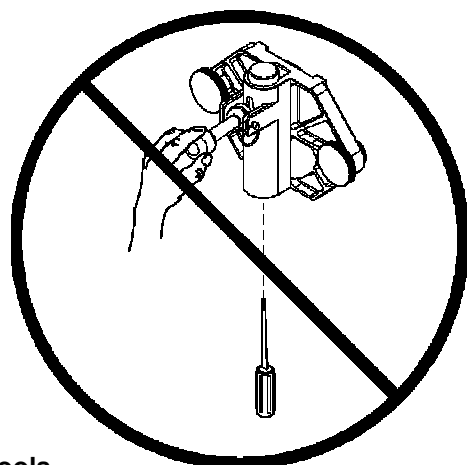
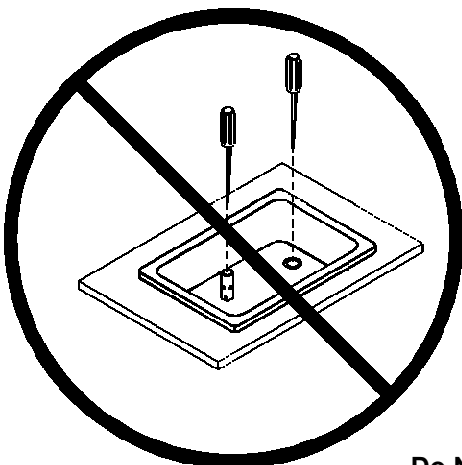

Fig. 26
Do Not Insert Objects or Tools

Operation (Filling and Starting)

Always start with a cleaned and sanitized dispenser as per previous instructions. Use only fresh mix when filling the units. Following these instructions is critical to the maximum operating efficiency of the machine.

1. Set Control Switch to the “OFF” position.
2. Place a 16 oz. cup under the spigot and open the spigot handle. Pour approximately one quart of fresh product mix into the mix pan. (This will chase the sanitizing solution from the mix pan and freezing cylinder.) Close the spigot handle when the sanitizer is purged from the system.

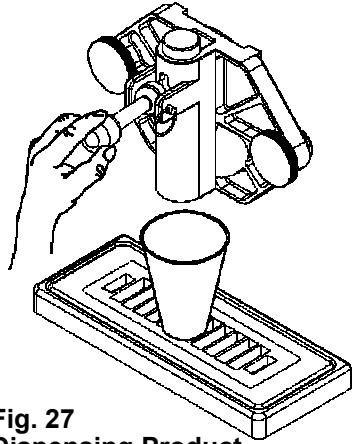

Fig. 27
Dispensing Product

3. Fill the mix pan with chilled, properly mixed product. Keep the mix level in the mix pan at least one inch (25 mm) deep at all times to avoid starving the freezing cylinder. A **MIXOUT** light (Fig. 28) located on the front of the machine is activated when the mix solution drops to a potentially damaging level.

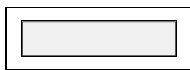

Fig. 28
MIXOUT Light

4. Set the control switch to the “**AUTO**” position to start the machine.

5. Allow the compressor to cycle 3 or 4 times dispensing a sample of the product after each cycle to check for consistency. If the machine is not dispensing the product at the desired consistency after four full cycles, refer to the Consistency Control Section of this manual. Initial pull-down time is 20-30 minutes, but it may vary due to product and ambient conditions.

6. Replace the mix pan lid and always operate the machine with the lid on the mix pan reservoir.

Note: SaniServ dispensers are designed to run frozen beverage products having a Brix (sugar content) range of 12.5 to 14 with a dispense temperature of 26°F to 28 °F (-3.3°C to -2.2°C).

Brix reading is taken by placing a small sample of normally diluted concentrate on the viewer of a refractometer. If a refractometer is not available, contact the mix supplier.

Do not use a mix with a Brix reading of less than 12.5. Doing so may result in serious damage to the machine.

If the Brix reading is above 14.0 or the alcohol content is too high, the freezing point of the solution may be too low to form slush.

DO NOT ATTEMPT TO MAKE FROZEN BEVERAGE USING ARTIFICIALLY SWEETENED PRODUCT.

WARNING

Control Switch Positions

“CLEANOUT” Position: The dasher motor operates continuously and the compressor will not come on. The mix out level sensor will turn on the “**MIXOUT**” light (Fig. 28) but will not activate the beeper.

“AUTO” Position: The dasher motor operates continuously. Upon machine start up the compressor will run until proper product consistency is reached. Then the compressor will shut off. Approximately every 10 minutes thereafter, the machine will test the product

consistency, and the compressor will cycle on if it is needed. If the liquid level sensor detects a low level condition, it will flash the “**MIXOUT**” light and activate the beeper for three minutes or until the mix pan is filled to satisfy the mix level probe. If the beeper is activated for more than three minutes, the light will begin to glow continuously, the beeping tone will slow down, and the machine will no longer dispense product.

Helpful Hints

Front Plate: This component is the plastic device from which the product is dispensed. It is designed and manufactured for strength and durability. However, through improper use, the front plate can be damaged. Use the following information for proper care:

- a. Do not over tighten the knobs.
- b. Always tighten knobs evenly. Do not attempt to turn one knob all the way down and then one of the other three knobs. Doing so will bind the front plate and could result in breakage.
- c. Improper installation of the stator rods can cause breakage. The stator rods must be properly seated in the dasher before installing the front plate. If the stator rods are improperly installed, subsequent tightening of the knobs will break the front plate.
- d. **DO NOT** attempt to wash the front plate or any other components in a dishwasher.

Mix Out Light: When the mix out light comes on, the mix pan is low on mix. The mix pan must be filled with fresh product mix immediately to prevent air from entering the freezing cylinder starving the machine and causing freeze-up and vibration. If this condition occurs, set the selector switch to the "OFF" position. Add mix to the low mix pan until the freezing cylinder stops bubbling. Return the control switch to the "AUTO" position.

Filling: Always fill the machine with fresh product at the start of each day.

Drip Tray: This should be removed daily and cleaned to remove residue.

Mix Pan Lid: Be certain to leave the lid in place on top of the machine to prevent any foreign materials from contaminating the mix.

Mixing: Make certain that the product mix is prepared according to label instructions.

Sanitizing: Do not soak plastic parts in sanitizer overnight. Doing so can cause the plastic parts to become brittle and lead to premature failure.

Winter Storage: To protect the unit during seasonal shut-down, it is important that the dispenser be stored in the proper manner. Use the following procedures:

1. Turn off **ALL** power to the machine.
2. Wash all parts that come in contact with the mix with a warm mild detergent solution. Rinse in clear water and dry parts thoroughly.
3. Store the loose parts such as the mix pan components, front plate parts, and the dasher assembly parts outside of the machine.
4. Do not lay heavy objects on the plastic or rubber parts.
5. Cover the machine and all loose parts to protect them from dust or other contaminants while in storage. Place the machine in a dry location.
6. **On water-cooled units, disconnect the water lines. Use compressed air to blow out all remaining water in the condenser. Insert a screwdriver (Fig. 29) to open the water valve. Note: Failure to purge the machine of water can result in severe damage to the cooling system. This task should be performed by a qualified service technician.**

Closed Hours/Shut-Down: If the machine is turned off during closed hours, to resume operation:

1. Set the control switch to the "CLEANOUT" position.
2. Dispense two quarts (2 liters) of product into a sanitized pitcher and pour it back into the mix pan. Doing so serves as a mixing process to eliminate any overnight separation.

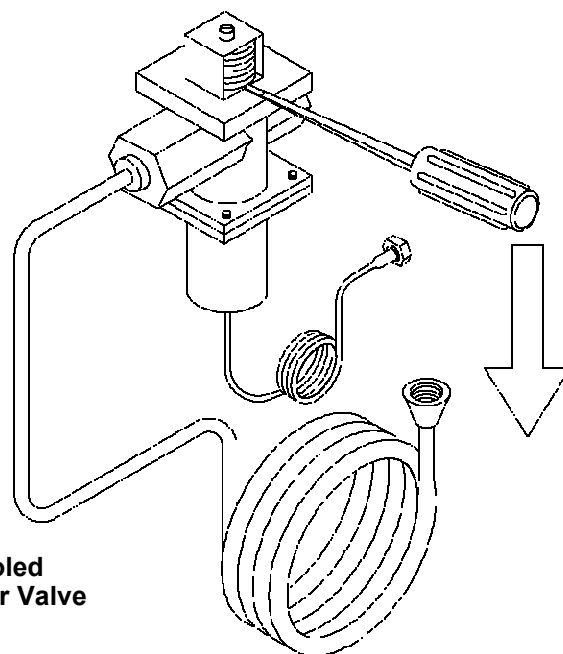

Fig. 29
Water-Cooled
Condenser Valve

Consistency Adjustment

CAUTION !

Adjustments to the Electronic Consistency Control System should only be made by a certified SaniServ service technician. DO NOT attempt to make adjustments or repairs on the machine.

This machine is designed with an electronic control board to manufacture **Frozen Slush Beverage Only!** Do not attempt to operate the machine with soft serve and or shake type products. Operating unit with soft serve or shake products will damage the machine and factory warranty will be voided.

DO NOT ADJUST THE MACHINE!
Improper consistency may be due to improperly mixed product

This equipment has been tested at the factory with slush product and has been shipped with FACTORY PRE-SETS. Non-Alcoholic beverage temperature will range from 25-28 degrees. Alcoholic beverage temperature will range from 17-22 degrees. If you feel a consistency adjustment is needed, check the temperature of the dispensed product before making an adjustment. If your product is within these temperature ranges and the consistency is incorrect, you may have improperly mixed product.

ADJUSTING THE MACHINE TO COMPENSATE FOR IMPROPERLY MIXED PRODUCT MAY CAUSE PRE-MATURE COMPONENT FAILURE AND MAY VOID WARRANTY.

Consistency adjustment is done by adjusting the potentiometer on the electronic control board (ECB). The ECB is located behind the front wiring box cover

**CAUTION
BEFORE PROCEEDING
DISCONNECT THE POWER**

above the front dispensing plate.

1. Remove two Phillips screws on the underneath side of the wiring box cover. The ECB is located on the left side of the wiring box as show in Fig. 30.
2. Locate the black potentiometer labeled **HARDNESS** as shown in Fig. 31. By turning the potentiometer to the right (clockwise) it will increase the thickness and lower the product temperature. Turning the potentiometer to the left (counter clockwise) will decrease the thickness and raise the temperature.
3. Reinstall the wiring box cover and reconnect the power.
4. Run the unit with product and allow the refrigeration system to cycle **TWO** times.
5. Draw product from the machine and check for desired consistency.
6. Repeat procedure if required.

NOTE: ONLY TURN THE POTENTIOMETER IN SMALL INCREMENTS.

Electronic Consistency Control

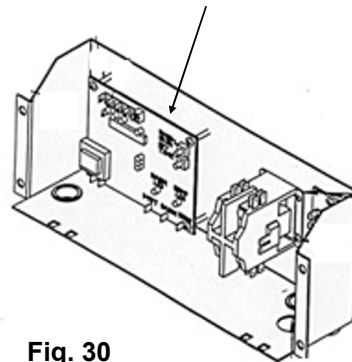
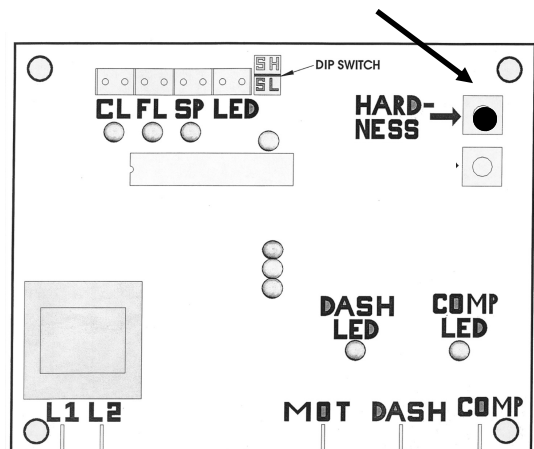

Fig. 30
Wiring Box

Fig. 31
Electronic Consistency Control



Routine Maintenance (Owner-Operator)



WARNING

DISCONNECT THE MACHINE FROM ITS POWER SOURCE(S) BEFORE PERFORMING ANY ROUTINE MAINTENANCE. PERSONAL INJURY OR DAMAGE TO THE MACHINE COULD RESULT IF THIS PRACTICE IS NOT OBSERVED.

Daily: Inspect the machine for signs of product leaks past seals and gaskets. If proper assembly does not stop leaks around gaskets or seals, check for improper lubrication and worn or damaged parts. Replace parts as needed.

Periodically: Inspect the scraper blades (Fig. 32) to see that they are straight and sharp. If worn, damaged or warped, the blades will not scrape the cylinder walls correctly and the freezing capacity will be reduced. Clean the drip chute assembly with warm water and detergent solution.

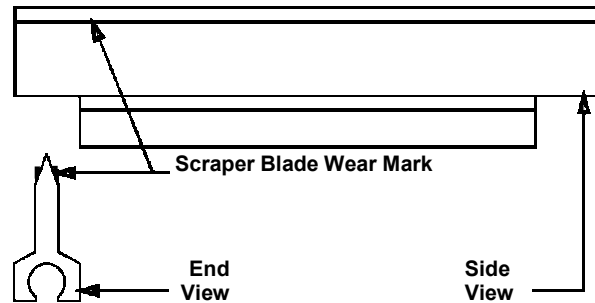

Fig. 32
Scraper Blade Wear Mark



Routine Maintenance (Trained Service Technician)



WARNING

**CONDENSER FINS ARE VERY SHARP
USE EXTREME CAUTION WHEN CLEANING**

Quarterly: Thoroughly clean the condenser fins on all air-cooled machines. Remove all lint and dust with a vacuum cleaner or compressed air (Fig. 33) to clean fins. A dirty condenser greatly reduces refrigeration capacity and efficiency. When using compressed air, place a damp cloth on the opposite side of the condenser to catch the flying dirt or lint.

Annually: Check the belts for signs of wear or cracking. Remove panels and clean all parts inside of the machine including the base, side panels, fan blades, condensers, etc.

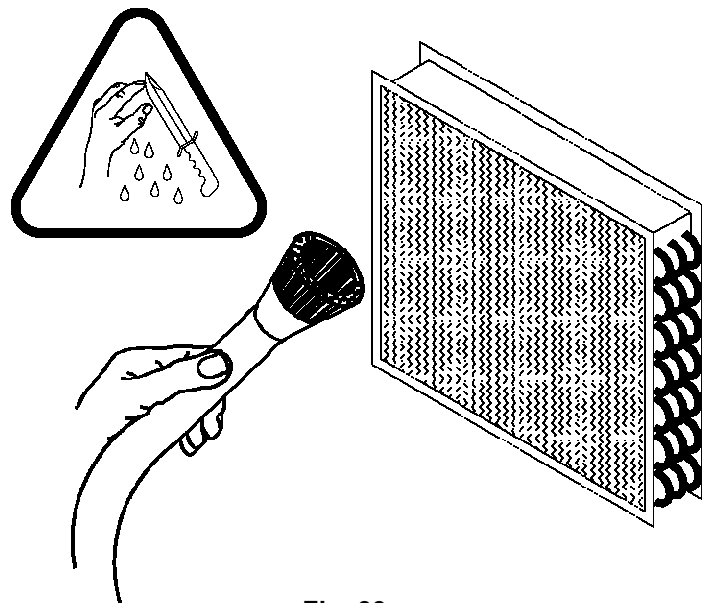

Fig. 33
Clean Sharp Condenser Fins

Please make these simple checks prior to contacting your service provider. Because adjustments to the machine are not covered under the terms of warranty, these tips can save you time and money. If you feel you are not comfortable performing trouble-shooting suggestions, please contact your local certified service provider.

Machine will not start	<ul style="list-style-type: none"> ✓ Make sure electrical cord is correctly seated in the electrical receptacle. ✓ Check circuit breaker in electrical panel.
Product is Soft	<ul style="list-style-type: none"> ✓ Do not make a consistency adjustment at this point. Always check product temperature first. Should be between 25-28 degrees non-alcoholic frozen beverage and 18-22 degrees alcoholic frozen beverage. See Product Breakdown in glossary section. Replace with fresh product. If using a frozen beverage product and temperature is lower than listed, product has too much sugar, alcohol or combination. Correct ingredients and start with freshly mixed product. ✓ Check for properly mixed product. Replace as necessary ✓ If using Re-run product, remove product and add fresh mix. ✓ Check for dull scraper blades. Blades should be sharp. Replace every 6 months. ✓ Check Condenser for dirt or obstructions. See Quarterly Maintenance ✓ Confirm that the condenser fan is running. ✓ Confirm 6" of airflow on all both sides and back of machine. ✓ High ambient temperature. Recommended machine ambient temperature not to exceed 82 degrees.
Product is too Thick	<ul style="list-style-type: none"> ✓ Check for properly mixed product. ✓ Confirm freezing cylinder is not starved of product. See glossary (Starved Cylinder) ✓ Check product temperature. Should be between 25-28 degrees non-alcoholic frozen beverage and 18-22 degrees alcoholic frozen beverage. ✓ Check for missing scraper blade or stator rod. Check dasher assemblies.
Front Plate Leaking	<ul style="list-style-type: none"> ✓ Confirm front plate o-ring is not ripped or torn. Replace if necessary. Replace seals and o-rings every six months. ✓ Do not lubricate front plate o-ring. ✓ Confirm spigot plunger o-rings are not ripped or torn. Replace if necessary. Replace every six months. ✓ Confirm spigot plunger o-rings are lubricated daily. ✓ Tighten front plate knobs evenly. ✓ Confirm stator rod is not worn or grooved.
Product leaking from the drip chute and or drip tube.	<ul style="list-style-type: none"> ✓ Rear Seal is worn. Replace. Note: Replace seals, o-rings and gaskets every six months. ✓ Do Not Lubricate the rubber portion of the rear seal ✓ The shaft of the dasher where the rear seal is installed must be lubricated daily. ✓ Confirm stator rod is not worn or grooved. ✓ Front plate knobs loose.
Squeaking , chirping noises and or vibration heard.	<ul style="list-style-type: none"> ✓ Use properly mixed product. Replace as necessary. ✓ Confirm freezing cylinder is not starved of product. See glossary (Starved Cylinder) ✓ Check lubrication ✓ Confirm all panel screws are installed and tightened ✓ Adjust width of drip tray bracket. ✓ Check for dull scraper blades. Blades should be sharp. Replace every 6 months.
Compressor Runs Continuously	<ul style="list-style-type: none"> ✓ This is normal for the Model 798. Refrigerant is directed to each freezing cylinder independently based on the electronic consistency control system.
Who to contact for service and parts	<ul style="list-style-type: none"> ✓ If you do not have a local service and parts provider, contact your SaniServ Dealer/Distributor. Visit www.saniserv.com to locate a Distributor (Sales Section) or a Service Agent (Technical Support Section).

Trouble Shooting Glossary

Ambient Temperature. The temperature of the air in the immediate vicinity of the operating machine. High ambient temperature can reduce the capacity with an air-cooled condenser.

Capacity. The total capacity of frozen product that a freezer can produce in a given period usually stated in gallons per hour (G.P.H.).

Condenser. The part of the refrigeration mechanism that receives hot, high-pressure refrigeration gas from the compressor and cools gaseous refrigerant until it returns to a liquid state.

Consistency. The viscosity or thickness of the product in the freezing cylinder.

Consistency Control. A control that senses the thickness or viscosity of the product in the freezing cylinder.

Dasher. The part of the freezer that scrapes frozen product off the inside of the freezing cylinder and blends the product. In a gravity freezer, this assembly also moves the product forward to be dispensed.

Front Plate. Seals the front of the freezing cylinder and provides a means for dispensing the product. On gravity fed freezers, the front plate indirectly holds the dasher in place via the stator rod. It also provides compression for the rear seal.

Front Plate Pressure Relief Valve. Spring-loaded button located on the front plate when depressed will allow air to escape from the cylinder. Used only on specific frozen beverage machines.

Freezing Cylinder. The part of the refrigeration mechanism in which the refrigerant vaporizes and absorbs heat. This is the part of the freezer where the liquid product is frozen.

Mix-pan. Is the top container that product is poured into. It is used as storage until product is needed for the freezing cylinder.

Mixing Product / Product Temperatures. If your using a product that has to be mixed with water or other ingredients, it is imperative the product is mixed consistently everyday. If not, the machine will not run consistent and could possibly damage components. Always mix to the product manufactures recommendations. The machine is designed to operate with a frozen product that falls within these temperatures (non-alcoholic frozen beverage 25-28 degrees and alcoholic frozen beverage 18-22 degrees).

Rear Seal. This part is stationary during operation and must not move. When installed and lubed properly, seals mix in cylinder. When installed and lubed improperly, it causes main shafted bearing failure.

Scraper Blades. The component that scrapes the frozen product from the freezing cylinder surface. Blades must be sharp, as dull blades will leave product on the freezing cylinder, insulating the mix from the refrigerant.

Spigot Plunger. The mechanism on the front plate through which the product is dispensed.

Starved Cylinder. A starved cylinder is often mistaken for a freeze up or product too thick. A starved cylinder (starving) is created when a larger percentage of frozen product is dispensed from the freezing cylinder than the percentage of liquid product entering the freezing cylinder from the mix-pan. There are several causes of starving.

1. **Overdrawing:** Dispensing more product from the machine than it's designed to do. This would occur if a machine were undersized for its application.
2. **Mix out light not working** therefore not alerting operator the need to add product.
3. **Pouring frozen or semi frozen product** into the mix-pan reservoir. This will form a blockage in the restrictor tube and not allow liquid product to flow into the cylinder.
4. **Mix-pan too cold,** allowing product to freeze in mix-pan and restricting product flow.
5. **Restrictor tube installed into the rear hole,** should be installed in the front hole of the mix-pan reservoir.

Stator Rod. Acts as a bearing surface. Helps enfold air for overrun. Transmits compression to the rear seal. Helps mechanical torque system sense torque. Be sure to lubricate.

Notes



451 E. County Line Road
P.O. Box 1089
Mooresville, Indiana 46158-5089

www.saniserv.com

Free Training Video Available Online



<http://fb.saniserv.com>



Proudly made in the U.S.A.

Technical Publication
80851
Updated 06/15