

Advanced by Design



- SELF-SERVE DESIGN
- HEAVY DUTY CONSTRUCTION
- REMOVABLE & DURABLE POLYCARBONATE DOORS
- SHELVES HOLD STANDARD SHEET PANS
- SMALL FOOTPRINT
- DESIGNED FOR MAXIMUM PRODUCT VISIBILITY
- HOLDS AND DISPLAYS
- MODULAR DESIGN



PHONE: 403-255-7712

TOLL FREE: 800-265-7711

ADDRESS: 9298 Horton Road S.W., Calgary, AB, Canada T2V 2X4

FAX: 403-255-1725

E-MAIL: profits@perfectfry.com

WEB: www.perfectfry.com



DIMENSIONS

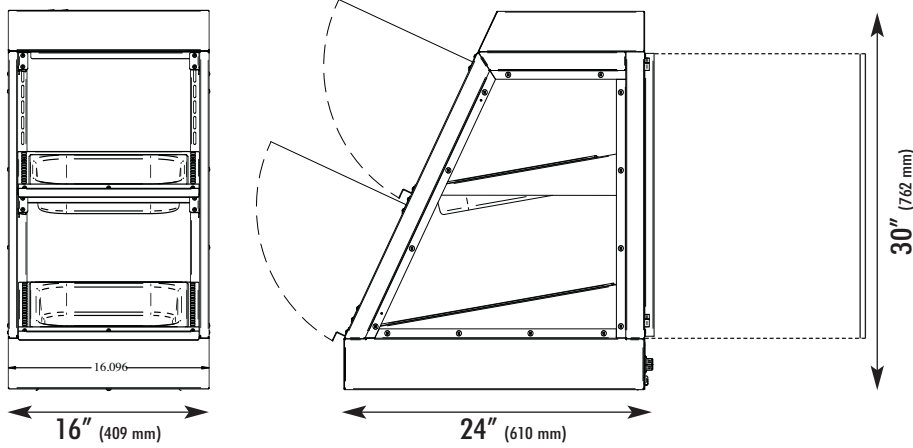

AIRFLOW DIAGRAM

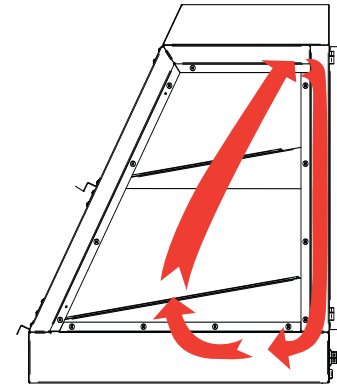

Air Temperature is controlled by consistent convection heating.

SPECIFICATIONS TABLE

MODEL	PFM 1250
POWER SUPPLY (volts)	120
CURRENT (amps)	10
CIRCUIT CURRENT (amps)	15
NEMA NUMBER	5-15
POWER (kilowatts)	1.25 kW
PAN CAPACITY (2"/51 mm deep)	2/3 Top, Full-size Bottom

OPTIONS & ACCESSORIES

WATER TRAY
#6SM022

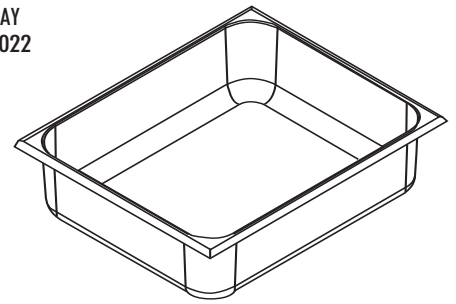

GENERAL SPECIFICATIONS

- Phase Single (3 wire)
- Cycles 50/60 Hz
- Heat Range 70°F to 170°F (21°C to 77°C)
- Heating Format Radiant & Convection Heating
- Weight 70 lb (32 kg)
- Shipping Weight 85 lb (39 kg)
- Shipping Dimensions L29" – W22" – H34"
(737mm – 559mm – 864mm)
- Shipping Cube 12.55 cubic ft.
(.3559 cubic metres)

RECEPTACLE CONFIGURATION

